

Agent Release

Item Number: 4310-0011

Installation guide

Description

The Agent Release System comprises of the Main Control Card, Termination Board and Local Control Stations. In addition a yellow Manual Call Point can be supplied to fit to the main Fire Alarm Control Panel (FACP).

The Agent Release Add On consists of;

- The Agent Release Card.
- The Agent Termination Board.
- 1 x 220mm and 350mm RJ45M Comms cable.
- 1 x 250mm 2 way IDT Termination Brd. power cable
- 8 x Mounting screws and 4 X standoffs.
- 2 x EMI Suppression Ferrite

Installation

Observe anti-static precautions at all times

Agent Release Card

1. Power down the FACP and remove the batteries
2. From inside the FACP remove the blank panel by depressing the 2 top and bottom retaining clips while at the same time pushing it out through the front panel.
3. Insert any card designator labeling and clip the card in its place.
4. Set the address as required and insert LK1 if necessary.
5. If applicable fit and cable (Figure 2) the optional Agent Release MCP
6. Select a suitable cable length from those supplied to connect CN6 to the internal RS485 comms on the Main Control Board of the FACP or, CN7 of the previous front panel card of the FACP

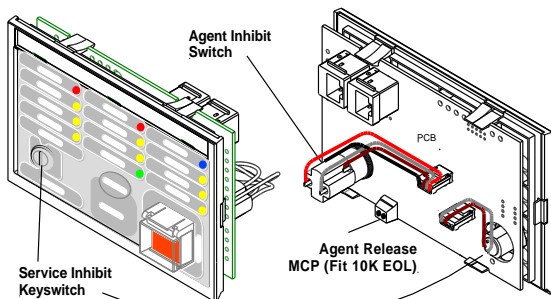

Figure 1: Agent Release Card

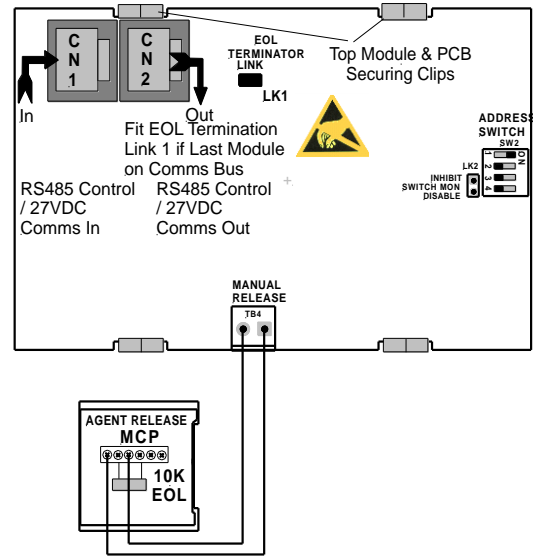

Figure 2: Agent Release Card rear view

Agent Termination Board

1. If necessary fit the stand offs for the Termination Board to the back pan.
2. Mount the board onto the standoffs using the 4 M3 X 6mm screws.
3. Select suitable cables from those supplied and connect to the Main Control Card as outlined in Figure 3
4. Connect Local Control Station, Gas Release, Pressure Switch, Low Pressure Switch and Interlock Lock as per Figure 4
5. Connect Warning Signs as per Figure 4. Up to 6 signs are supported from the termination board.

Note 1: Warning Sign wiring will need to be wired thru the supplied EMI Suppression Ferrites as shown in Figure 4

6. Power up, reconnect batteries, program, isolate the agent and test

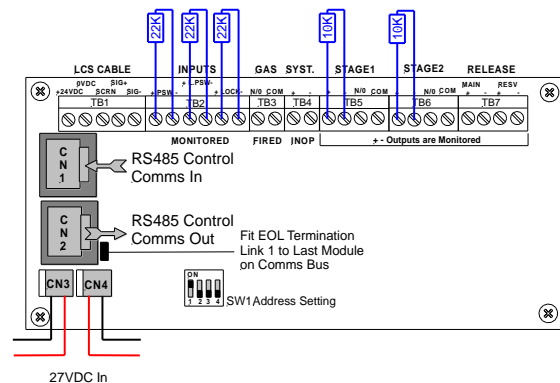

Figure 3: Agent Termination Board

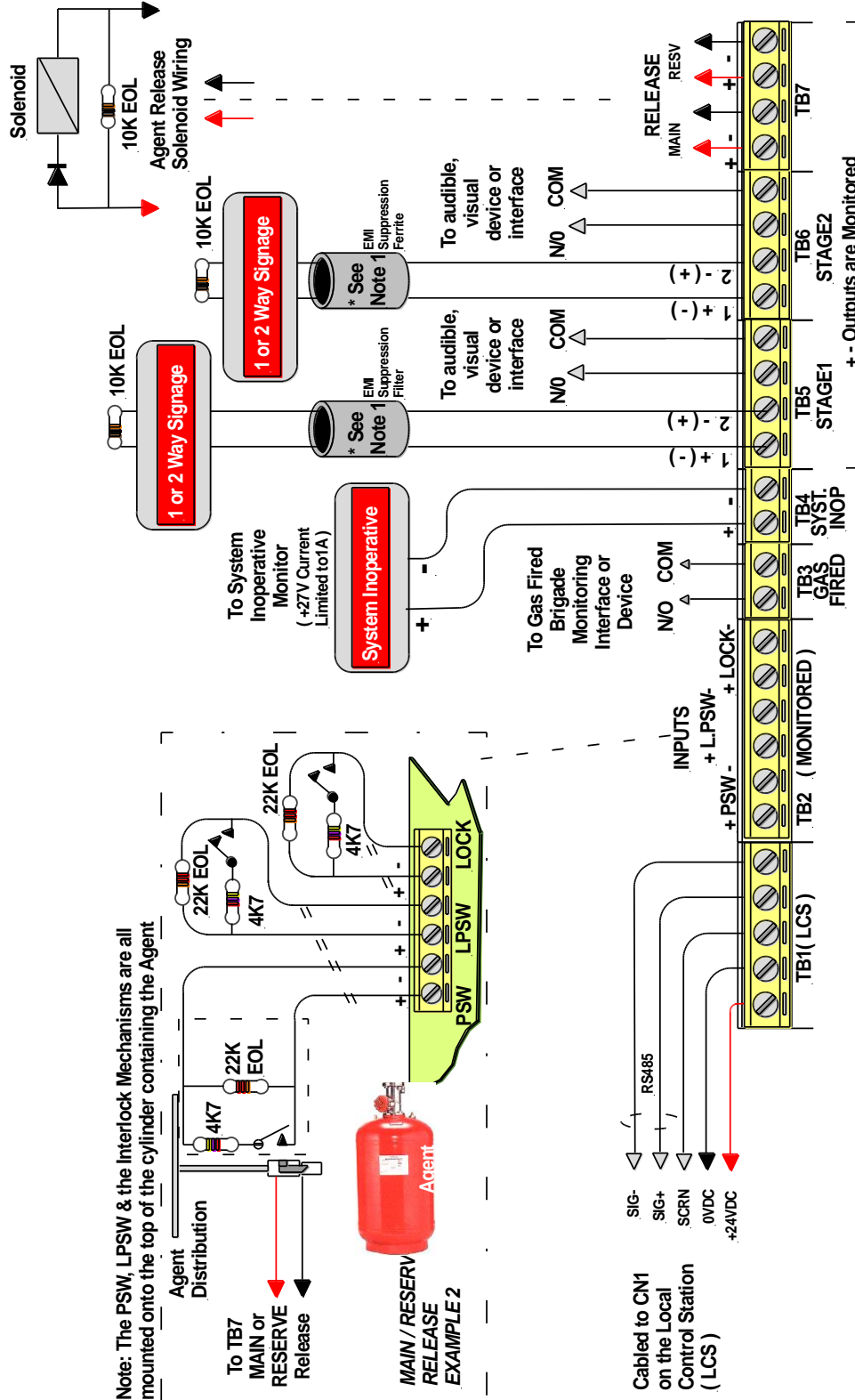
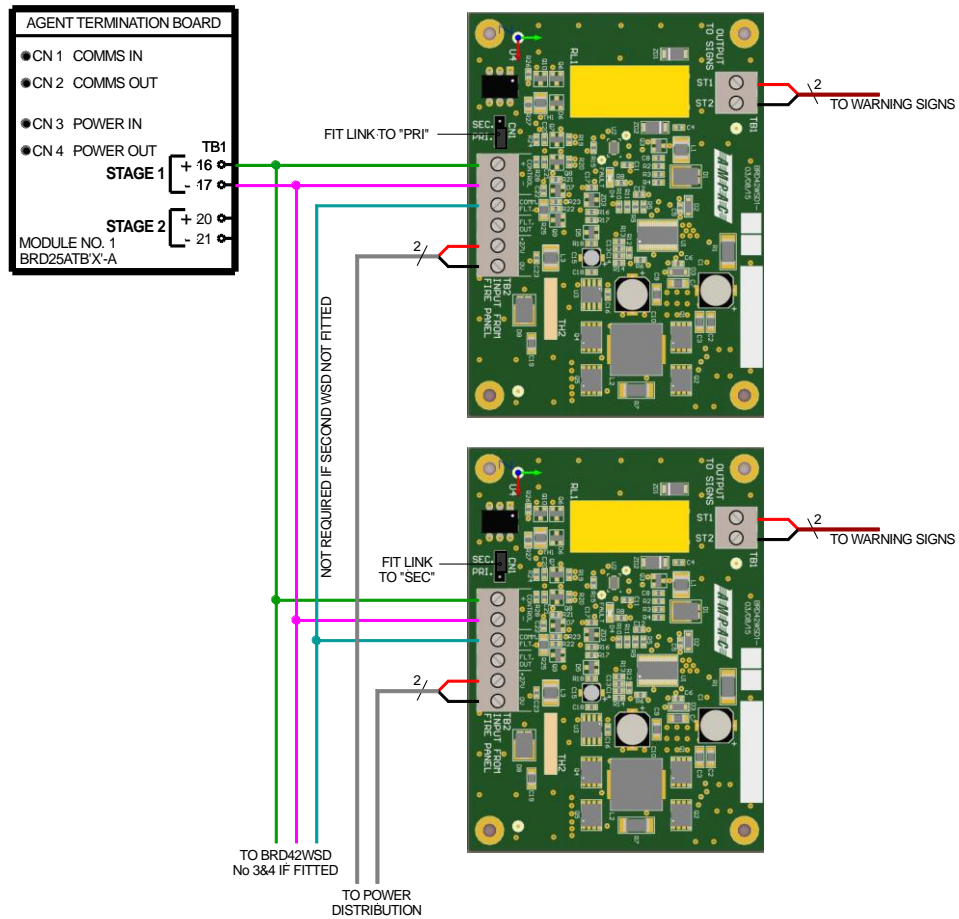

Figure 4: Typical Cabling to the Agent Termination Board

Warning Sign Driver Kit

Where more than 6 warning signs are required, the Warning Sign Driver Kit (4210-0121) shall be used.

The following shows the connection of the Warning Sign Driver PCB to the Agent Release Board.



Recommended maximum number of signs according to cabling

Cable length*	Cable size mm ²		
	0.75	1.0	1.5
50	12	12	12
100	12	12	12
150	8	10	12
200	6	8	12
	Number of signs		

*Cable length is specified as a pair, standard TPS copper cable. The return path is included in the calculation.