



THIS EQUIPMENT MUST ONLY BE INSTALLED BY A SUITABLY SKILLED AND TECHNICALLY COMPETENT PERSON. ENSURE THE PANEL IS ELECTRICALLY ISOLATED PRIOR TO INSTALLATION.



Anti-static handling guidelines

Ensure that anti-static handling precautions are taken before handling the panel's PCBs, or any other static-sensitive components. Before handling any static-sensitive items, operators should rid themselves of any personal electro-static charge by momentarily touching any sound connection to safety earth. Always handle PCBs by their sides and avoid touching the legs of any components.

Introduction

The Output Expansion Relay Board (see figure 1) is designed to mount inside the **GasRelease** Panel. When connected, it provides five isolated (voltage-free) relay outputs which are directly controlled by the **GasRelease** panel.

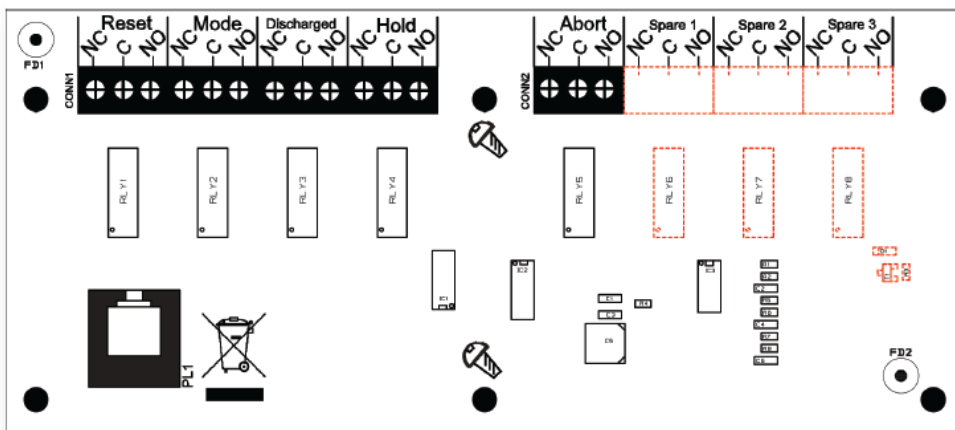

Figure 1 – Output Expansion Relay Board PCB Layout

Functions

Important: The outputs of this product are rated for switching up to 30Vdc 1A signal circuits only and ARE NOT designed to switch Mains voltages.

The relay functions are listed below:

- Reset:** Changes over when the panel's "Reset" pushbutton has been pressed, or a remote reset input has been received at the panel. Stays in this state for at least one second after all other outputs have normalised. Typically used for resetting fire detection devices.
- Mode:** Changes over when the gas system's mode is changed to manual. The system can be toggled between Manual Only and Manual & Automatic by turning a mode select keyswitch at the **GasRelease** panel, Remote Status Unit (RSU), Economy Status Unit (ESU) and other devices.
- Discharged:** Changes over when a released flow switch input (from a flow switch in the gas pipework) has been received at the panel. This indicates the gas has been released.
- Hold:** Changes over when a hold input has been received at the panel. If the panel is in the 2nd stage alarm condition (i.e. it is in automatic mode and detection circuits are activated, or it is in either automatic and manual mode and a manual release input is operated) then the gas release sequence is halted. Typically used for connection to remote emergency equipment.
- Abort:** Changes over when an abort input has been received at the panel. This will cancel the gas release sequence. Typically used for connection to remote emergency equipment.

Installation

Note: The **GasRelease** panel's metal base unit houses the Main Control PCB, the Power Supply PCB and an optional Output Expansion Relay Board. The Main Control PCB is mounted on a metal bridge and the Power Supply PCB and Output Expansion Relay Board are mounted on the base unit underneath the Main Control PCB.

To fit the Output Expansion Relay Board:

1. Isolate the Mains supply from the Gas Release panel and disconnect the battery back-up supply.
2. Disconnect the Main Control PCB to Power Supply PCB telecoms-style data connection cable from PL3 on the Power Supply PCB.
3. Slacken the four M4 retaining nuts on the metal bridge and slide the bridge (and mounted Main Control PCB) up and over its mounting pillars. Take care not to damage any components. Store the Main Control PCB in a safe place.
4. Decide which of the Output Expansion Relay Board's connections are going to be used and remove the necessary knockouts on the top of the base unit.
5. Position the Output Expansion Relay Board in the base unit (see figure 2). Slide the board over and downwards securing onto its mounting pillars, taking care not to damage any components.
6. Fix the two (M4 x 8mm) Pozi Pan retaining screws on the board. DO NOT over tighten the screws otherwise their threads will strip.
7. Make off the system cables to the board's screw connectors as required. The system cables must be routed away from the Power Supply PCB.
8. Plug the telecoms-style data connection cable (supplied in the accessory pack) into PL1 on the Output Expansion Relay Board. This connector simply pushes in until it 'clicks'. When removing this connector, be sure to press the connector's release tag before pulling it out.
9. Plug the other end of the board's data connection cable into SKT1 on the reverse of the Main Control PCB. Plug the Power Supply PCB to Main Control PCB data connection cable back into PL3 on the Power Supply PCB.
10. Slide the metal bridge (and mounted Main Control PCB) over and downwards securing onto its mounting pillars. Secure the bridge into position using the four M4 retaining nuts.
11. Reattach the battery back-up supply and reconnect the Mains supply to the panel.

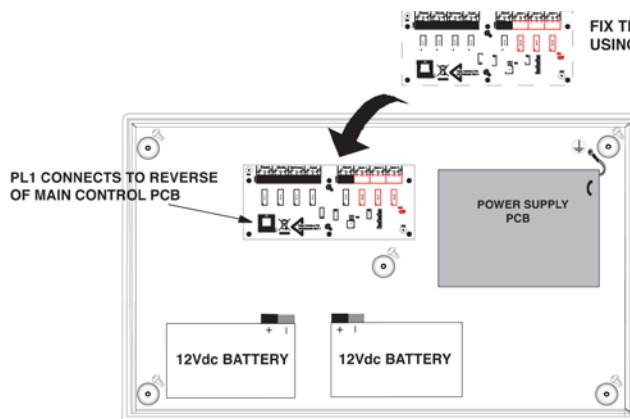

FIX THE OUTPUT EXPANSION RELAY BOARD USING THE TWO MOUNTING HOLES PROVIDED

Figure 2 – Fixing location of Output Expansion relay board

Note: Gas panel is shown with lid and Main Control PCB removed

Technical Specification

Output Expansion Relay Board	
Max cable size	1.5mm c.s.a.
Max Number of boards per panel	1
Number of volt free relay contacts:	5 (Reset, Mode Switch, Discharged, Hold, Abort)
Relay Contact Rating	30Vdc, 1A Max. Note: DO NOT switch Mains voltage
Accessory Pack	
1 x Installation Instructions; 2 x keys; 1 x Relay Board, 1 x RJ45 Lead, 2 x (M4 x 8mm) Screws, 2 x M4 spring washers, 2 x M4 flat washers.	