

Fire detection and evacuation solutions that save lives.

Weatherproof IP65 Door Holder

Features

- IP65 Ingress Protection
- Robust Steel Construction
- 1200N (122kg) Holding Force
- 24V DC or 230V AC Supply Voltage
- Supplied with Keeper Plate
- Wide Operating Temperature

Description

The Weatherproof Door Holder is ideal for most applications in all types of buildings while its high level of ingress protection means it is particularly suited to use outdoors and in marine type applications.

The Weatherproof Door Holder has been designed to hold open fire doors for convenient access through busy doorways and to release them for closing when an alarm is triggered. The Weatherproof Door Holder is wall mounted and is supplied complete with a keeper plate for fixing to the fire door. Both parts are manufactured from steel and are zinc plated.

Electrical protection is provided via an IP65 connector supplied with the unit.

Assembly

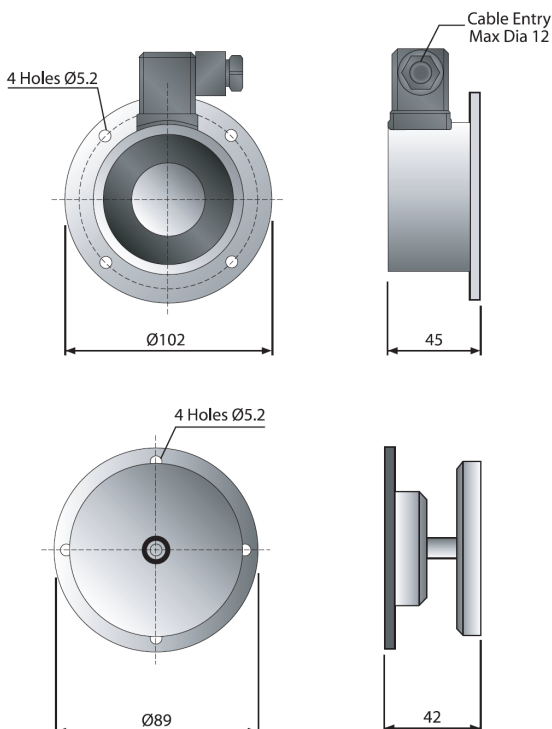

Surface Mount Door Holder

Item Numbers

4101-5001	IP65 Protected 1200N 24Vdc
4101-5002	IP65 Protected 1200N 230Vac

Specifications

	4101-5001	4101-5002
Operating Voltage	24V dc	230V ac
Current	300mA	45mA
Holding Force		
Newtons		1200N
Kilograms		122kg
Dimensions		
Assembly		Ø 102mm x 45mm
Keeper Plate		Ø 89mm x 42mm
Magnet Weight		2.0Kg
Manual Release		No
Operating Temp.		-30° to +80°C
IP rating		IP65
Finish		Zinc Plated Steel