

Warning Sign – Installation Guide

Item Numbers – 4210-0110 & 4210-0120

Introduction

The AMPAC Warning Signs provide clear, visual and audible indication of an alarm event and are designed for use with fire detection and alarm systems which may incorporate agent release capability. The display may also be customised as required to cater for a variety of applications.

The Warning Signs are available in two standard formats, the 4210-0110 for semi-flush or surface mount indoor applications while the 4210-0120 affords IP65 weatherproof capability for outdoor applications.

The Warning Signs incorporate a split level design that enables two text messages to be independently controlled through the application of input voltages. The two levels may be activated by either a voltage reversing DC input or through application of a common positive and two switched negative DC inputs.

Option switches located inside the unit enable the commissioning engineer to further configure the Warning Sign for continuous or flashing Red or Yellow LEDs, enable an integral buzzer in continuous or pulsing mode of operation, to enable a mute facility to silence the buzzer and or optional external sounder. A facility to synchronise the flashing between multiple signs is also provided.

Illuminated using the latest in high efficiency, high intensity LEDs to greatly reduce power consumption and increase reliability ensures that the brightness is maintained even when running on depleted stand-by batteries.

Note: A maximum of 6 AMPAC Warning Signs can be connected to the output of the Agent Release Board.

Installation (4210-0110 enclosure)

Open the outer door using the plastic key device provided. Using the back box as a template, mark the position of the four fixings in the required position on the mounting surface. For semi-flush fixing applications, cut a hole in the mounting surface to the dimensions shown below ensuring adequate depth is provided for the unit to be recessed.

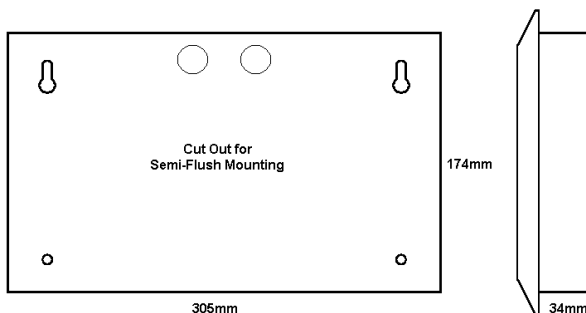

Before fixing the unit decide which entry points are to be used for the in-coming cables. The back box has 7 20mm knockouts in the top and bottom which can be

easily removed by sharply tapping them with a blunt instrument and hammer.

Top entry is recommended on this product however, back entry can be achieved by drilling additional holes in the back box to suite. Fix the back box to the mounting surface using 4 appropriate sized bolts or screws and install the acrylic text fascia plate using the 6 screws provided.

Installation (4210-0120 - weatherproof enclosure)

The weatherproof enclosure should be surface mounted using appropriate fixings and sealing washers.

- Using the 6x outer screws, remove the clear Perspex lid.
- Using the 4x black dome nuts, remove the text legend fascia plate bezel.
- Remove the internal printed circuit board using the 2x screws located in the centre of the PCB.
- Drill 4x 4mm fixing holes in the rear of the back box near each corner and fix the back box to the wall using appropriate fixing screws or bolts. Ensure that a watertight seal is maintained around the fixing holes.
- Re-instate the printed circuit board and fit the acrylic text legend to the fascia plate bezel using the 6x M4 nuts provided.
- It is recommended that the fascia plate bezel complete with acrylic text legend should be re-instated following initial testing of the system.

Cabling

The maximum size of cable that the terminals will accommodate is 2.5mm². The interconnecting external cables should be connected to the back box using suitable cable glands. On the 4210-0120 back box, waterproof lock-tight glands should be used to ensure a weatherproof seal is maintained. Ensure that cable tails of sufficient length are maintained to reach the terminals without cutting across the front surface of the internal printed circuit board as this will impair the illumination of the sign.

The Warning Sign can be configured to illuminate in two ways. For voltage reversal, 2 wire applications and for use with the AMPAC Agent Release module, refer figure 1. For common positive, switched negative 3 wire applications, refer figure 2.

Configuration Switches

The Warning Sign can be configured to operate in a variety of ways using DIL switches located on the printed circuit board. Table 1 outlines the functionality of the on-board switches located at SW2, switches 1 - 8.

SW1 controls the colour of the LEDs during the operation of the sign, Red or Yellow and should be set to suit the application of the Warning Sign.

Warning Sign – Installation Guide

Item Numbers – 4210-0110 & 4210-0120

Table 1

Switch	Off	On
1	Level Two Extinguished for Stage 1 Input.	Level Two Illuminates for Stage 1 Input.
2	Level One Illuminates for Stage 2 Input	Level One Extinguished for Stage 2 Input.
3	Level 1 LEDs Constant	Level 1 LEDs Flashing
4	Level 2 LEDs Constant	Level 1 LEDs Flashing
5	Buzzer Disabled	Internal Buzzer Enabled
6	Buzzer Continuous	Buzzer Pulsing
7	External Mute Input Enabled	External Mute Input Disabled
8	Output Synchronizing Disabled	Output Synchronizing Enabled (enable on first sign only)

Figure 1 – Two Wire Voltage Reversing Connection (AMPAC Agent Release Module)

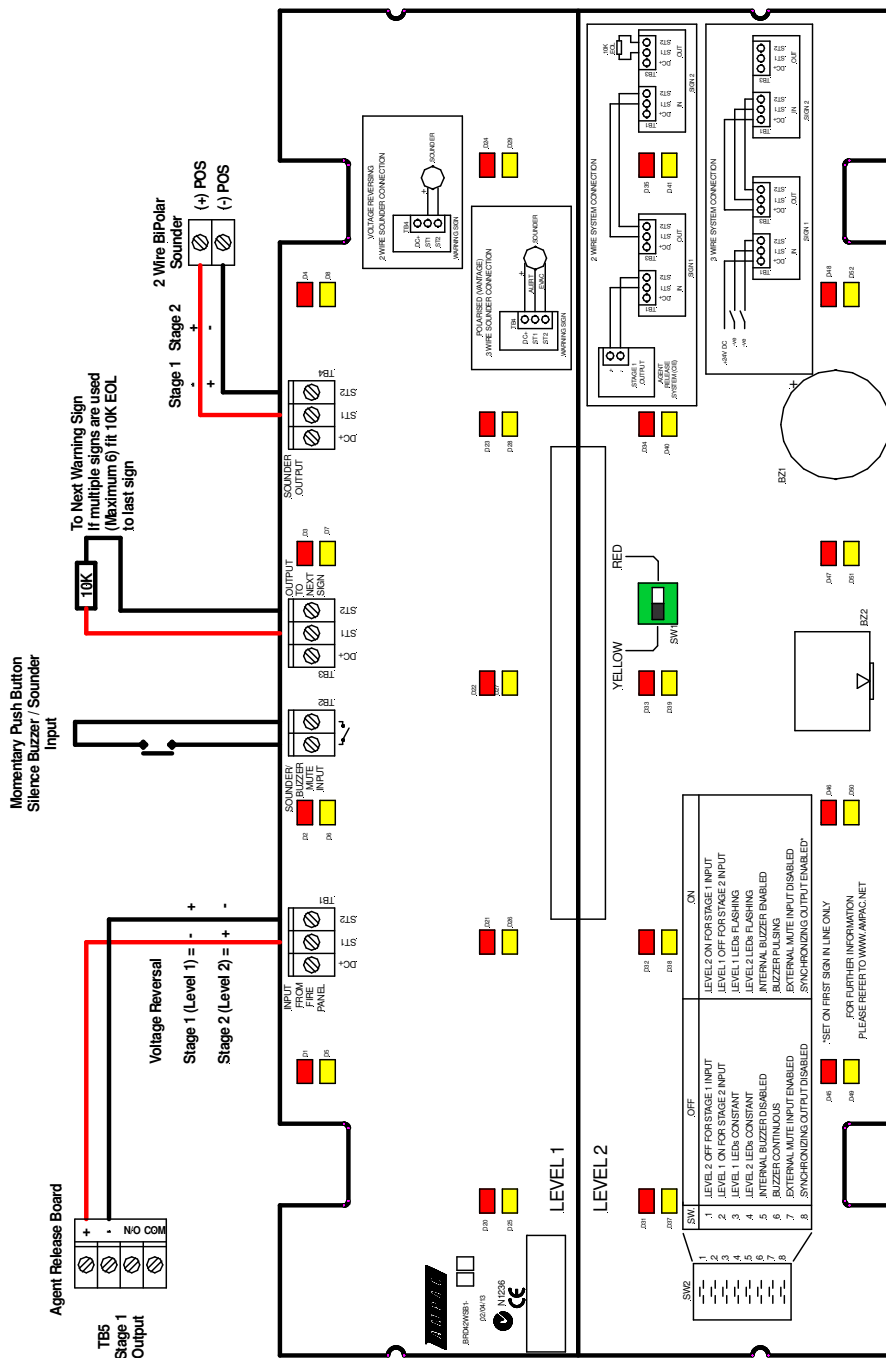

Warning Sign – Installation Guide

Item Numbers – 4210-0110 & 4210-0120

Figure 2 – Polarised 3 Wire Connection

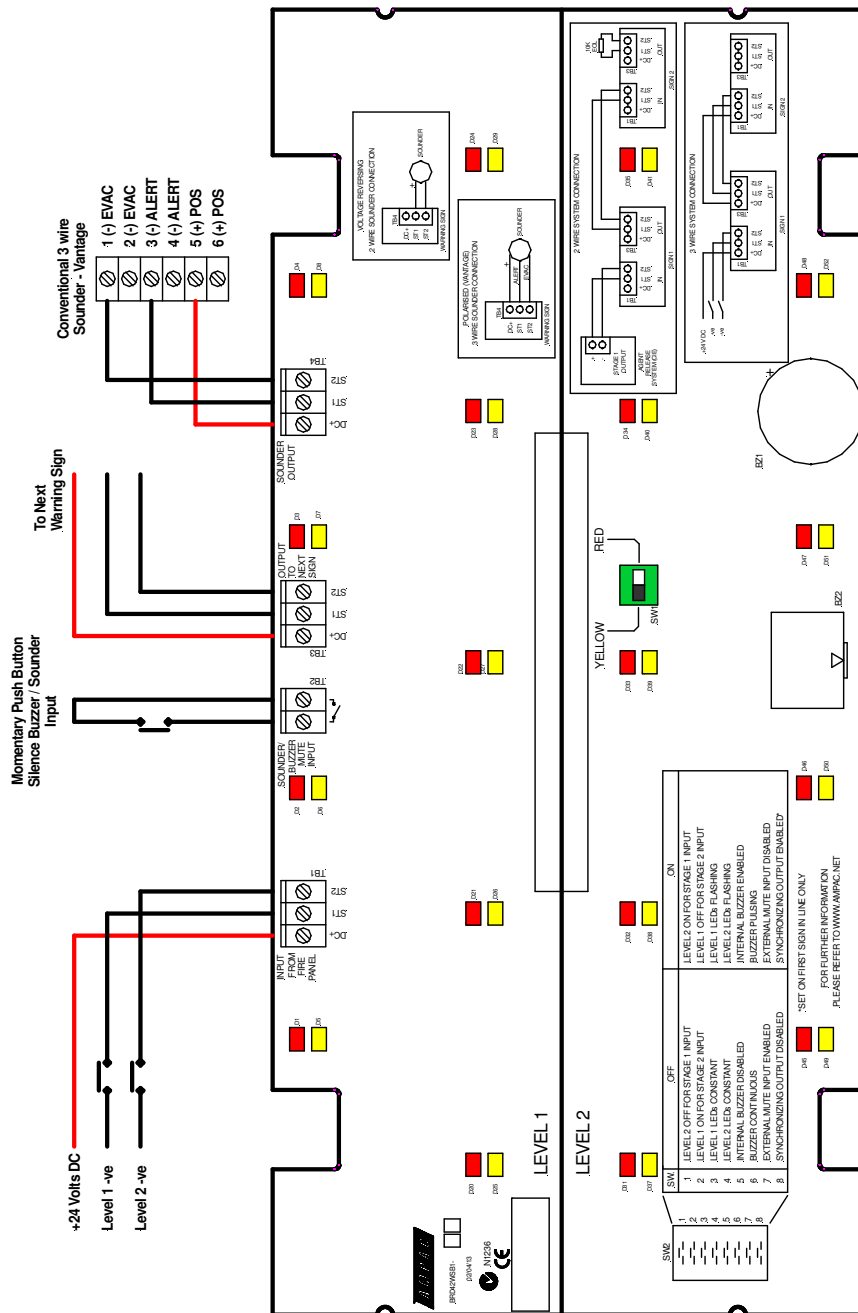

Buzzer / Sounder Mute

The mute input is enabled using SW2-5. The input should be connected to a normally open volt free contact incorporating a momentary action.

Sounder Output

A conventional sounder incorporating two separate tones can be connected to the Warning Sign. The sounder can be a two tone, bipolar type with a voltage reversing input or a polarised type, incorporating two switched negative inputs and a common positive input (Vantage). The type of sounder used does not rely upon the configuration of the incoming feed from the main control panel. It is recommended that only one sounder be connected to each Warning Sign as the output is current limited to 125mA to protect against short circuits. The output protection circuit, once activated will remain latched until power is removed from the sign.

AMPAC Technologies, 7 Ledger Road, Balcatta, Western Australia, 6021
 Tel +61 8 9201 6100 Europe +44 (0) 1302 833 622 New Zealand +64 9443 8072