

OPCARD-8

Output Card Consisting of 8 x Sw -ve O/Ps & 8 x VFCO Relays

PRODUCT OVERVIEW

OPCARD-8 has been designed to provide up to 16 common or zonal outputs. The card consists of 8 x switched -ve outputs and 8 x volt free change over relays. A permanent 28v supply is required which can be taken from the 28v output on the main circuit board of the control panel. The card also provides a 28v output which can be utilised if driving additional relays from the sw -ve outputs.

Up to 4 output cards can be fitted to the control panel and linked together to provide up to 32 common or zonal outputs.

The outputs have several configuration options including common or zonal operation. The configurations are set up by a simple DIL switch selection which is described in this document.

CARD DETAILS

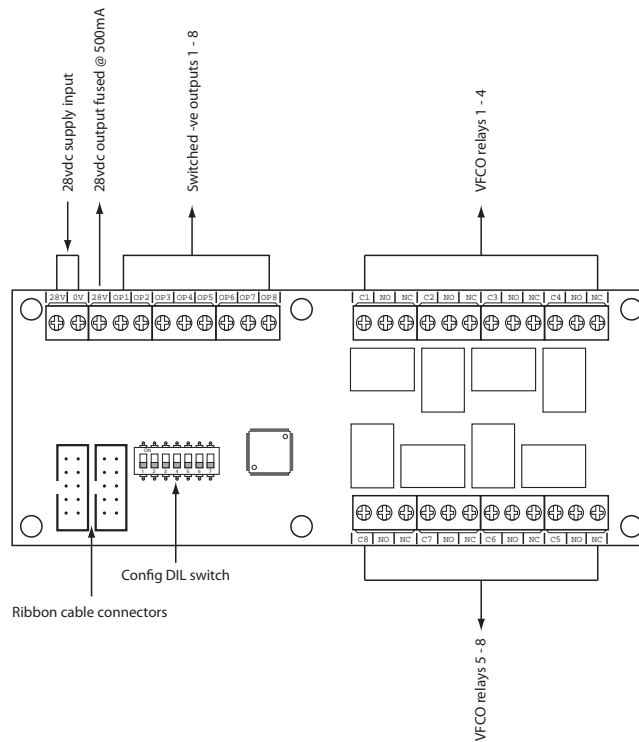

TECHNICAL SPECIFICATION

Electrical Specification Outputs - TPCA08 output PCB		
28v - 0v	Supply input	Max input current 5A. Input voltage 22vdc to 32vdc
28v	Supply output	Fused @ 500mA. Fuse = 500mA resettable fuse
OP1 - OP8	Switched -ve outputs	Overload voltage protected to 52vdc Current limited 680R Max load = 40mA per O/P
Relay Contacts 1 - 8 C - NC - NO	Clean changeover contacts	Unfused clean changeover Max 3A @ 30vdc

INSTALLATION 2-12 ZONE

The OPCARD-8 output card has been designed to fit into the control panel by piggy backing on top of the main circuit board using the fixing kit provided.

To fit the Output card, power down the panel, un-plug the display board ribbon cable from the main circuit board and plug it into one of the Output Card sockets instead. Then use the ribbon cable provided with the card to connect the Output Card back to the main circuit board from the second connector, see diagram below.

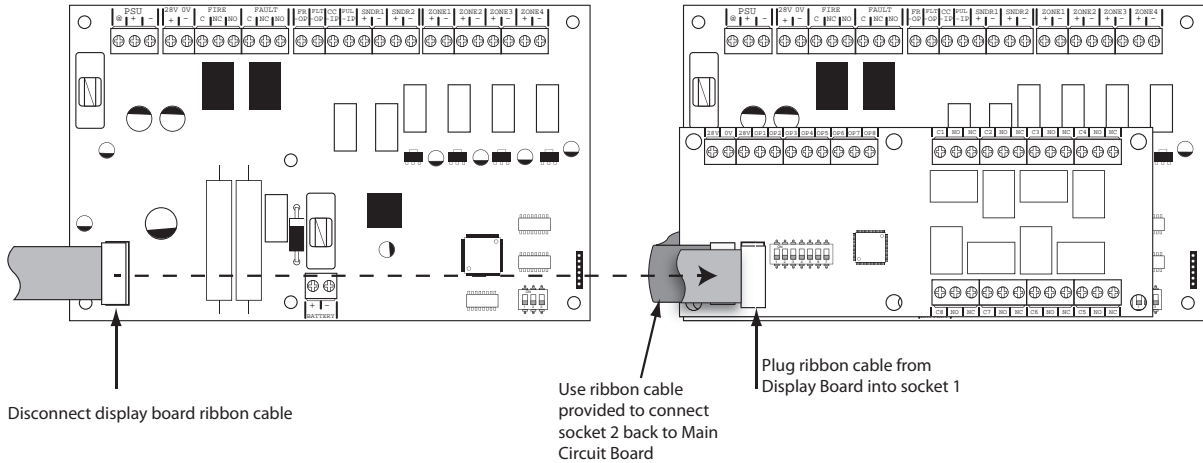

INSTALLATION 16-32 ZONE

The OPCARD-8 output card has been designed to fit easily into the control panel by clipping into pre drilled holes using nylon mounting pillars provided. Up to 4 cards can be fitted into each control panel and linked together via a ribbon cable (provided).

The display board comms ribbon cable will need to be disconnected from the main circuit board and plugged into the first output card. Each card has 2 ribbon cable connectors. The cards should then be linked with the ribbon cables provided with the last card then connected back into the display board comms connector on the main circuit board.

Each card also requires a 28v supply and therefore the 28v inputs will also need to be linked together using the wires provided.

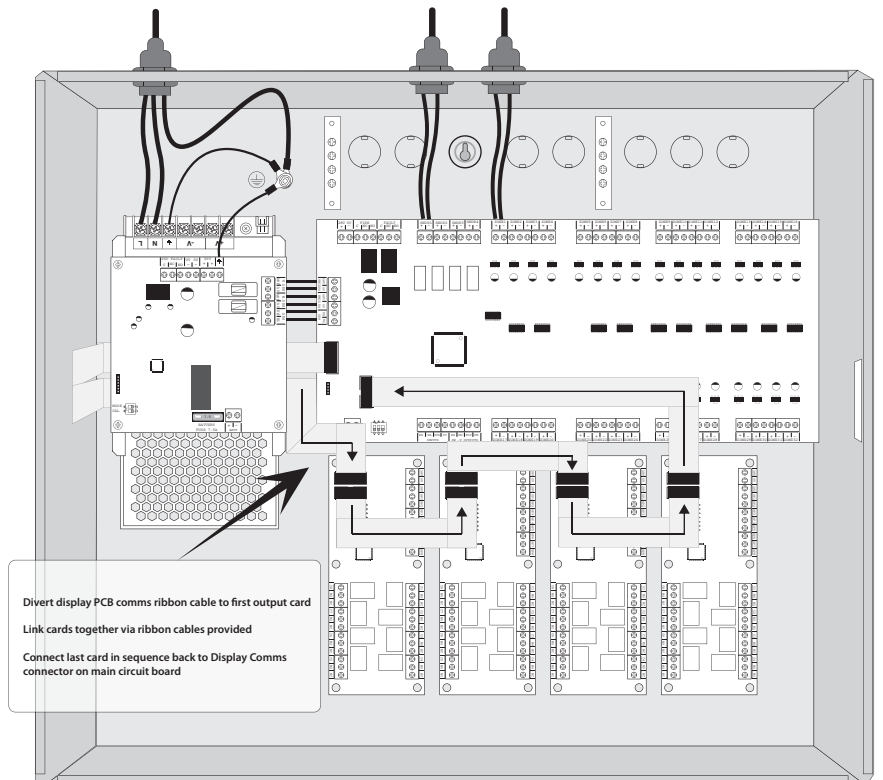

UP TO 4 OUTPUT CARDS CAN BE LINKED IN THE 16-32 ZONE CONTROL PANEL

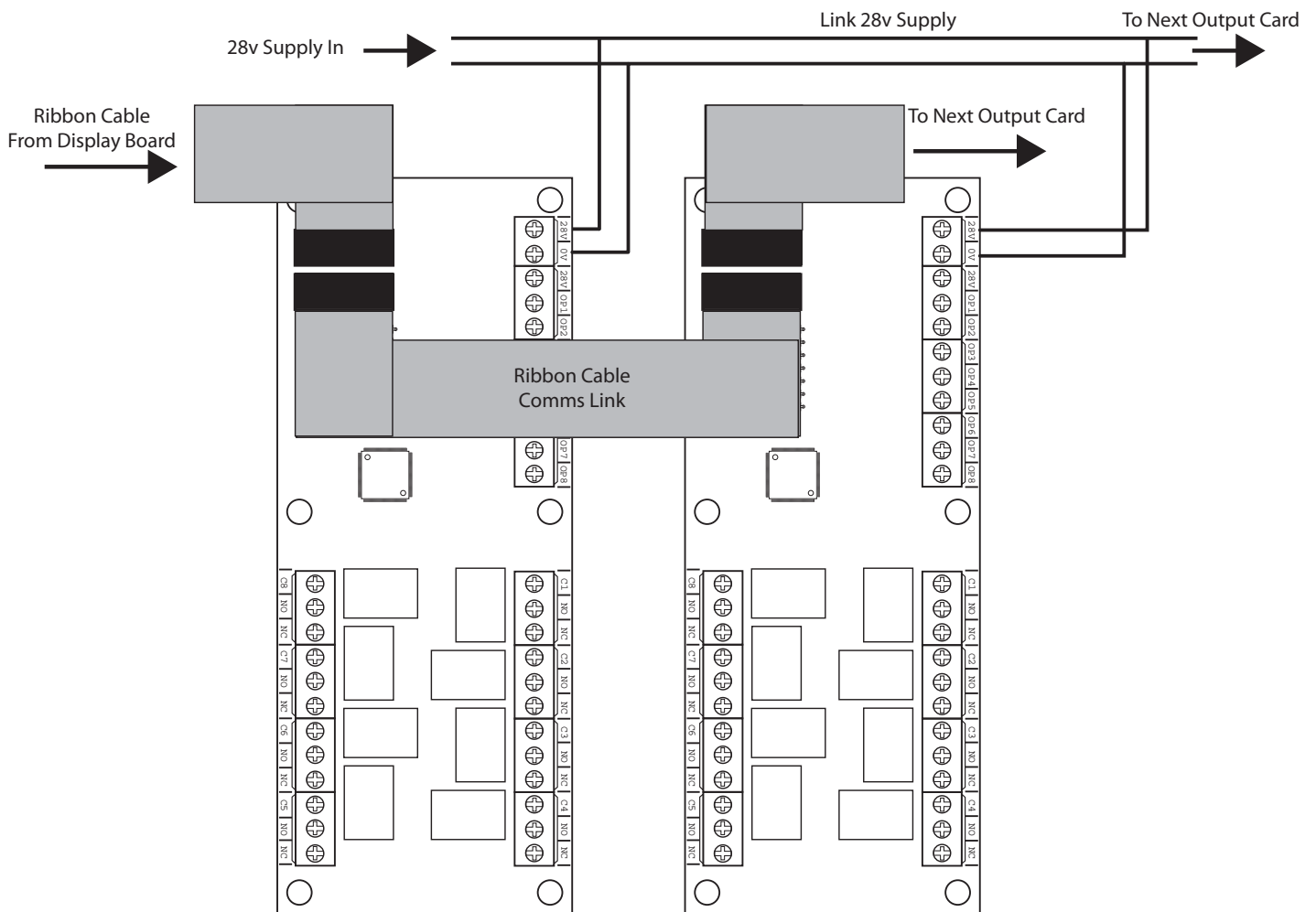

SETTING UP THE CONTROL PANEL

When installing output cards the control panel will need to be programmed for the number of cards installed.

Use Panel Wide Settings Programming Code 2 -1 -2 -3 Option 7, Set Number of Output Cards.

See programming instructions in the control panels' Installation, Commissioning & Operating manual for details.

SETUP

The outputs and relays 1 - 8 on each card can be set to operate common to all zones on the panel or to activate zonally.

The zonal operation settings are configured using the 7 way DIL switch located on the Output Card. In standard zonal operation mode the 8 outputs and relays will mimic 8 zones in the panel, i.e. zone 1 will activate OP1 & Relay1.

It is also possible to change the card to provide 16 zonal outputs where OPs 1 - 8 would mimic the first 8 zones in the range and Relays 1 - 8 would mimic the second 8 zones in the range.

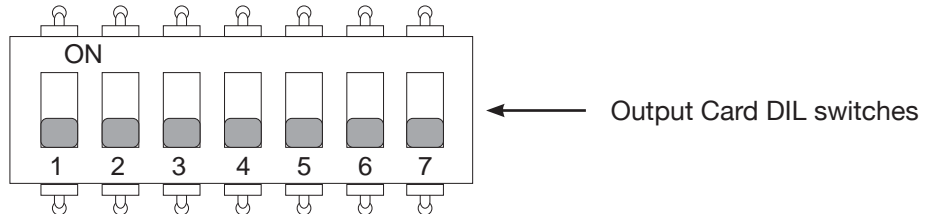

Switch 1

Sets whether the outputs operate Common or Zonally, OFF = Common ON = Zonal
If set to zonal, use switches 3 & 4 to set the zone range, see below.

Switch 2

Sets whether the outputs cancel on RESET or SILENCE ALARMS, OFF = RESET ON = SILENCE ALARMS.

Switches 3 & 4

These switches set the zonal operation zone range for the outputs to mimic. I.e both switches off - outputs and relays will mimic zones 1-8 etc.

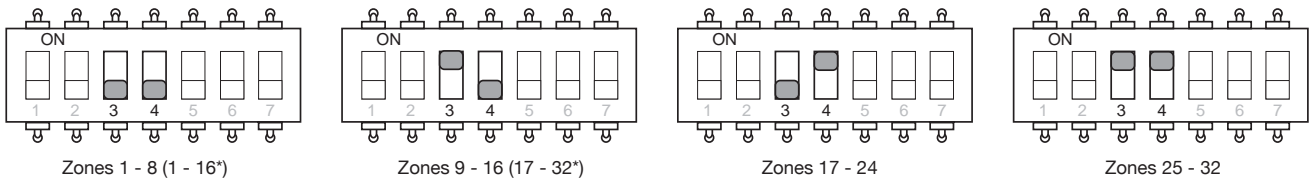

Switches 5 & 6

Each board will need to be given a unique address so the panel can identify it. This is done using switches 5 & 6.

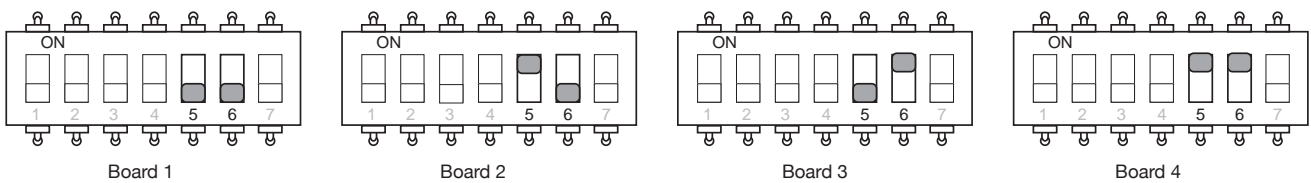

Switch 7

This switch converts the board to provide 16 zonal outputs where OPs 1 - 8 would mimic the first 8 zones in the range and Relays 1 - 8 would mimic the second 8 zones in the range. See zone range settings above *

OFF = 8 way (std) ON = 16 way