

Description:

The NZ Mimic Display is designed to provide remote indication of the current status of a NZ **LoopSense** FACP.

The mimic provides common Fire, Defect, DBA and system Normal indicators as well as up to 28 Zone Alarm Indicators.

The Board also provides connection for the Silence Alarm and Evacuation Key.

The NZ Mimic installation kit consists of;

- 1 x ASS4310-PANEL3-A (LED Mimic Panel A3)
- 1 x DEC2952-T1 (LOOPSENSE TRIAL EVAC Decal)
- 1 x BRD43LEDMX-A (NZ LED MIMIC BOARD (Fig 1))
- 12 x HW3033 (LED HOLDER CLEAR 5MM)
- 15 x HW1943 (CABLE TIE 100MM WHITE)
- 10 x HW1945 (CABLE TIE MOUNT 21MM (H4114))
- 1 x ENC3098 (LED Mimic Poly Carbonate A3 Window)
- 4 x HW1585 (SCRW M3x6MM P/H ST Z/P POZ)
- 8 x HW1816 (NUT M3 HEX ST Z/P)
- 12 x HW2102 (WASHER M3 S/PROOF INT TOOTH)
- 1 x CAB3012 (Trial Evac Keyswitch Assembly)
- 10 x LED2772 (LED Red 800mm leads (1 Fire, 1 DBA, 8 Zone))
- 1 x LED2773 (LED Yellow 800mm leads (Defect))
- 1 x LED2771 (LED Green 800mm leads (Normal))

Installation:

Observe anti-static precautions at all times

1. Prepare the Poly Carbonate sheet by Printing / Engraving the Floor Plan and drilling the LED Holes. Use a 1/4" Drill Bit to drill the LED holes which will accommodate the HW3033 LED Holder
2. Mount the Backpan and Poly Carbonate Mimic. This will depend on whether the panel is Front Service or Rear Service
3. Insert the HW3033 LED Holders into the Poly Carbonate sheet
4. Mount the PCB on the appropriate standoffs. Note: The position of the board will depend on the mounting of the cabinet. I.e. Front Service or Rear Opening (see Figure 3 & 4)
5. Fit the DEC2952 over the punch holes noting the orientation.
6. Fit the Trial Evac Key and Silence Alarm Key and connect to CN10 on the PCB (see Figure 3 & 4)
7. Fit the 4 Default LED's to the Poly Carbonate Mimic Panel, Fire (Red), DBA (Red), Defect (Amber) and Normal (Green) and terminate the leads to the BRD43LEDM (see Figure 2)
8. Fit the Zone LED's to the Poly Carbonate Mimic Panel and terminate the leads to the BRD43LEDM. Noting Zone positions on the MAP. (see Figure 2)
9. Power down the FACP, disconnect the batteries
10. Connect Power and Comms wiring from the Main FACP to the BRD43LEDM (see Figure 2)
11. Ensure Panel has been correctly programmed using LoopMaster (see Document No MAN2999) and the Address Switch is Set as per the Panel Configuration (See Figure 2)
12. Power up the FACP, connect the batteries and test using the Lamp Test on the BRD43LEDM Board

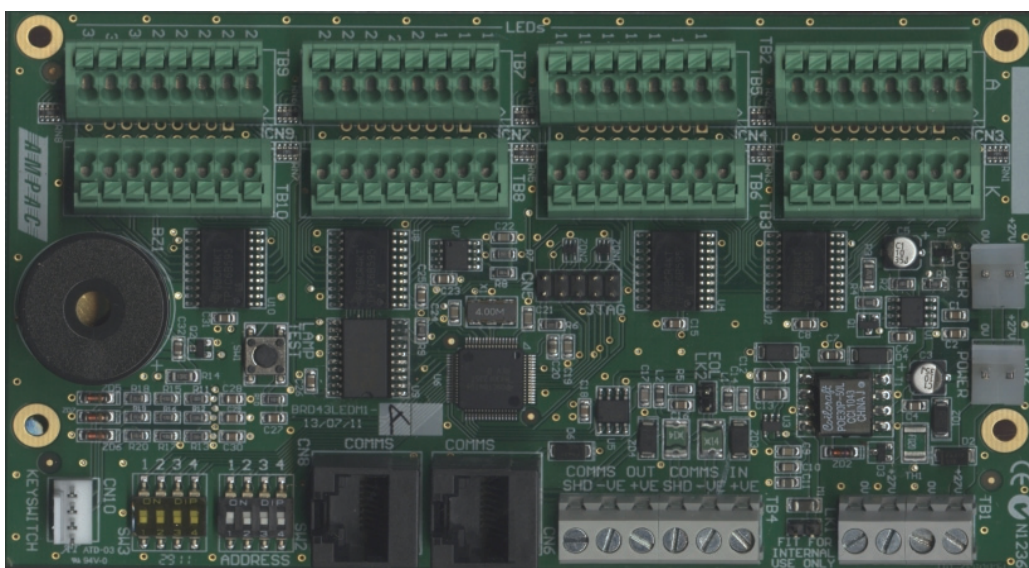

Figure 1: LED MIMIC BOARD (BRD43LEDM)

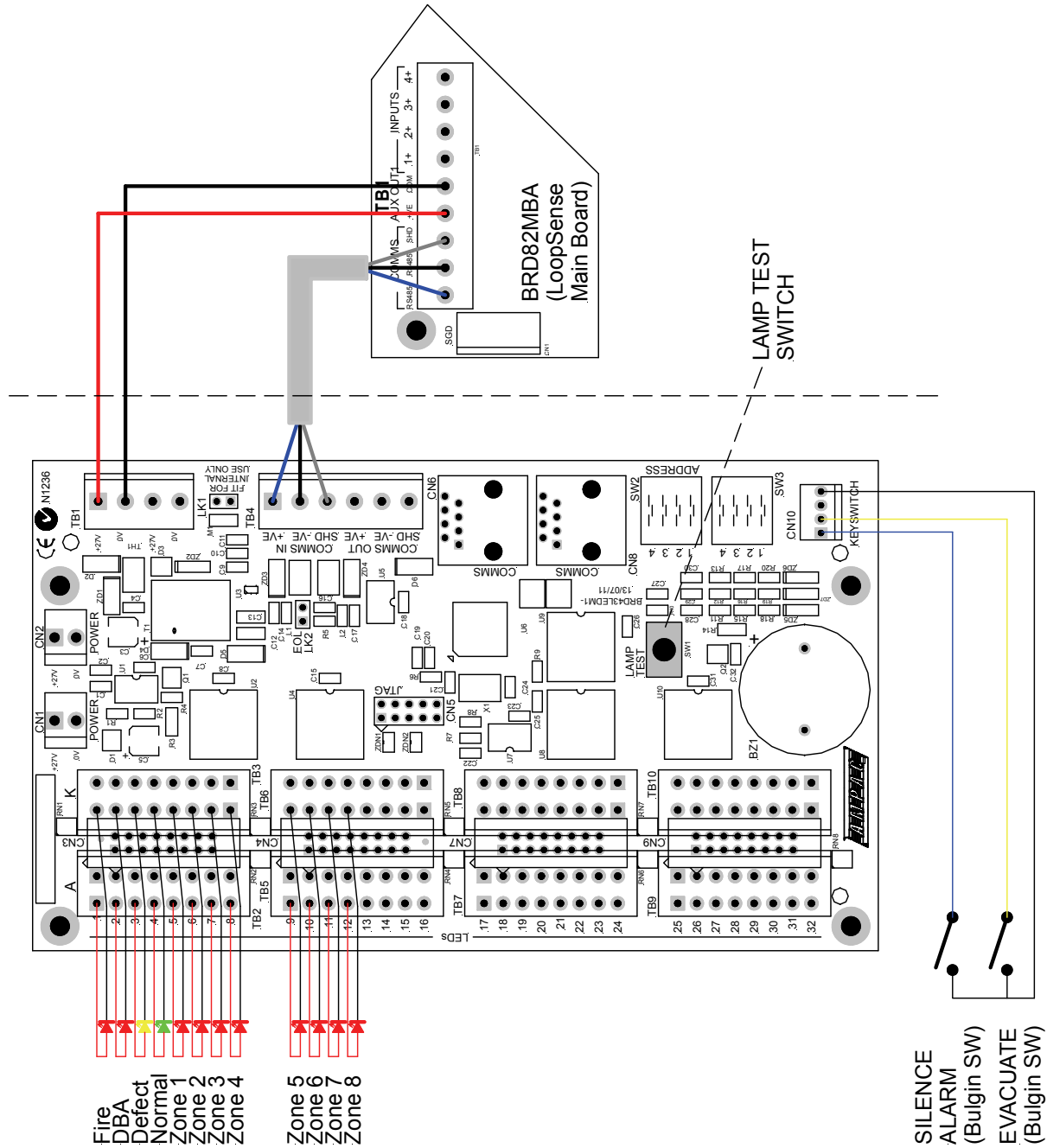

Figure 2: BRD43LEDM General Wiring Diagram

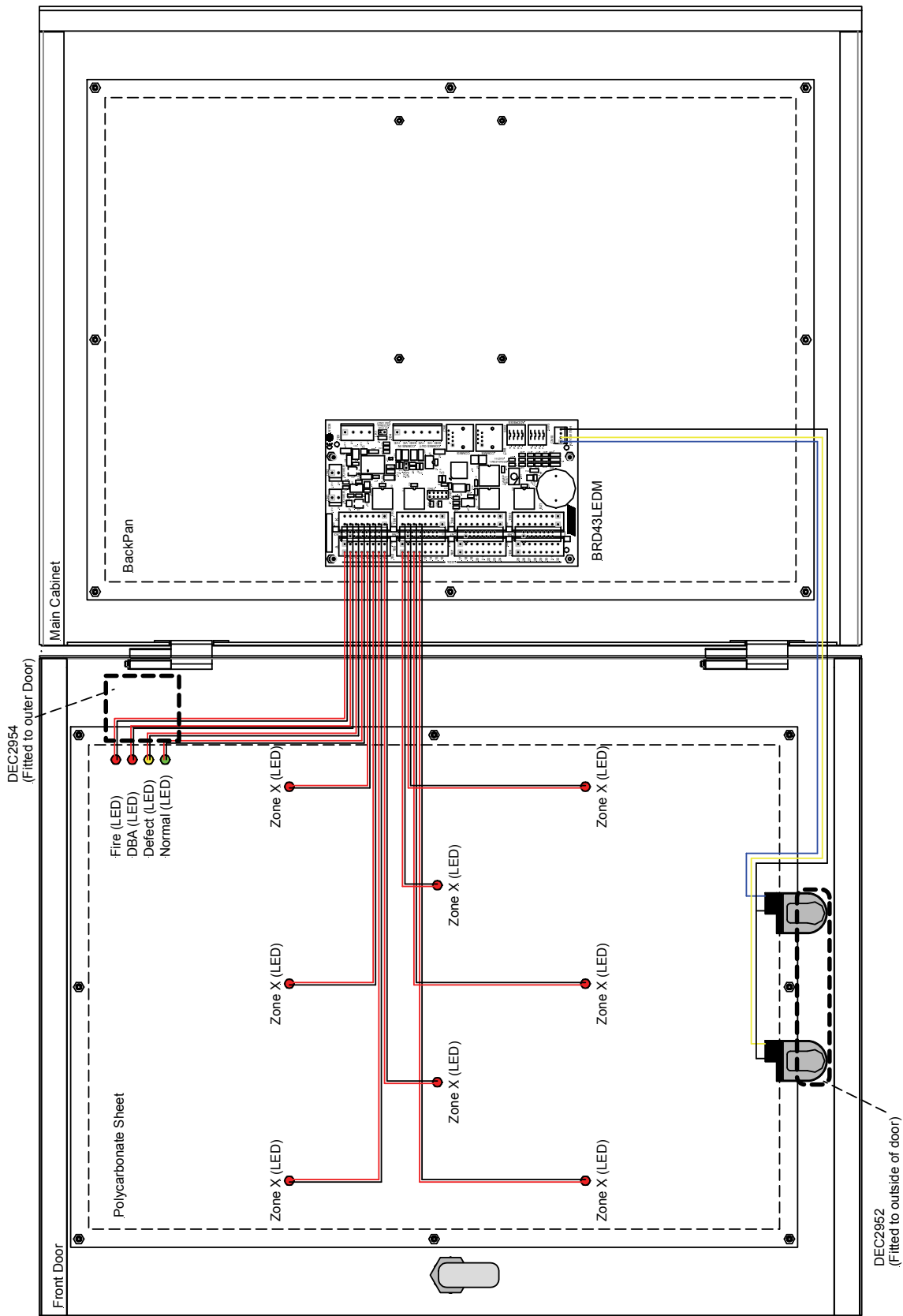

Figure 3: Front Service Mimic Panel General Layout

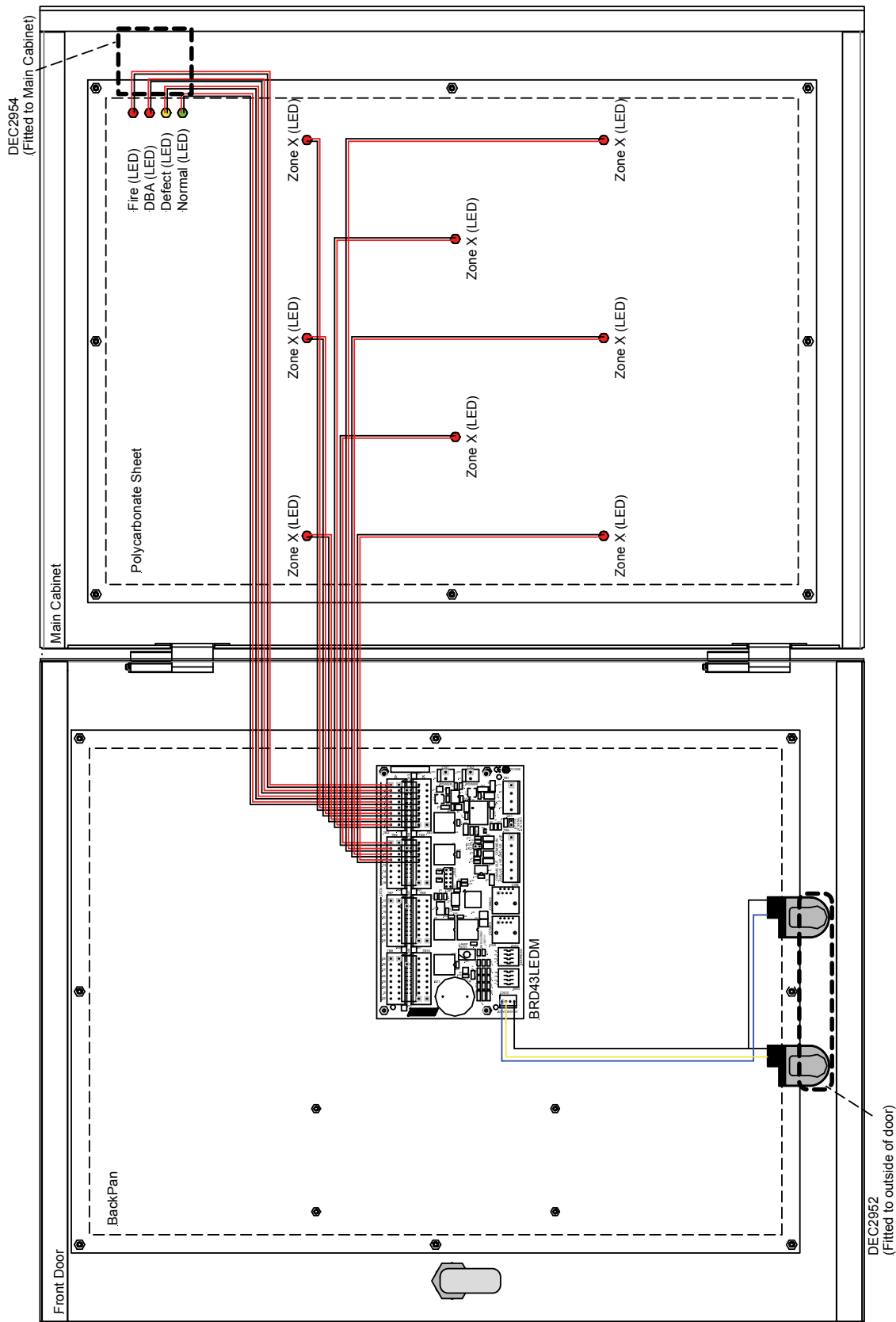

Figure 4: Rear Service Mimic Panel General Layout