

Isolator Specification

VSO, Isolate Voltage	13-16V
VSC, Reconnect Voltage	12-14V
IC, Continuous Current— Switch Closed	1A max
IS, Switching Current	3A max
IL, Leakage Current	300µA max

Conditions for Holding

The door will hold if all the following conditions are met:

- There is loop communication
- The device is fully initialised (minimum time would be 90 minutes)
- No faults on the device
- The device has a valid address (not 0 or 127)
- There is no Alarm condition indicated by the panel

Maintenance

Fire door holders should be tested weekly as part of the fire-system test procedures. For optimum holding force, the face of the magnet and keeper plate should be kept clean and free from damage. To comply with BS EN 1155, this device should not be used to hold open a door at less than 65°. There are no user-serviceable parts in this door retainer.

EMC Directive

The Addressable Door Retainer complies with the essential requirements of the EMC Directive 2014/30/EU, provided that it is used as described in this installation guide.

Construction Products Regulation (EU) 305/2011

The Addressable Door Retainer complies with the essential requirements of the Construction Products Regulation (EU) 305/2011

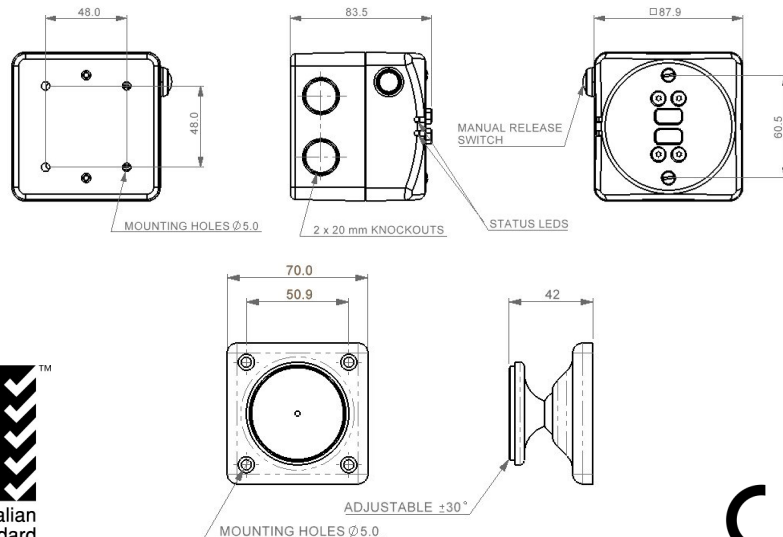

Cranford Controls Ltd
Unit 2, Waterbrook Estate
Waterbrook Road, Alton
Hampshire
GU34 2UD

Tel: +44 (0)1420 592444
Fax: +44 (0)1420 592445
www.cranfordcontrols.com
sales@cranfordcontrols.com

Addressable Door Retainer (ADR)



Product overview

Product: Addressable Door Retainer (ADR)
Part No: 55000-982CCL
Digital Communication: XP95 compatible
Address Range: 1-126 (not 0 or 127)

Product information

Door retainers ensure buildings are accessible for all by holding fire doors in the open position then releasing and closing them according to the fire system design. The Cranford Controls Addressable Door Retainer is an XP95 device designed for installation directly onto an addressable loop and is suitable for use on all types of fire door, including critical actuation doors.

- Integrated loop isolator
- Extra low voltage usage
- Suitable for critical actuation (Category A) installations*
- Failsafe by design
- Patented permanent magnet technology
- Doors and zones can be individually controlled
- 200N holding force rating
- Surface or semi-flush wall mounted
- Floor mounting options via standard bracket

*When connected to a compliant panel

Manufacturer's Specification

All data is supplied subject to change without notice. Specifications are typical at 24 V, 25°C and 50% RH unless otherwise stated.

Supply voltage	17 V to 35 V dc
Digital communication	XP95 compatible
Modulation Voltage	5 V - 13 V
Current Consumption Switch ON Surge and Quiescent	3.7 mA
EDL	4
Rated Holding Force	200 N
Initialisation and Self-Check Time	90 minutes minimum when loop power is present.
Typical Release-Hold Cycle	8 seconds (will release within 3 seconds)
Reed Switch Fault Recovery Time	5 minutes
Product Reset Option (Only when the ADR is holding or there is a reed switch fault)	Using the manual release switch: Hold switch for 10-19s, release switch for <5s and hold switch again for >10s. The reset will be confirmed by a constant green
Status Indicator (under normal operation)	<ul style="list-style-type: none"> Flashing Amber Every 5s - Charging Flashing Green Every 5s - Normal, Charged Continuous Amber - Isolator Active State or Fault, Charged Flashing Amber Every 1s - Isolator Active State or Fault, Charging
Operating temperature	0°C to + 40°C
IP Rating	IP3X
Vibration, impact and shock	EN 54-17:2005, EN 54-18:2005
Standards and approvals	EN 1155:1997 + A1:2002, EN 54-17:2005, EN 54-18:2005, CPR
Patent numbers for magnetic	European: EP1799944, UK: GB2450991
Dimensions	87.9mm wide x 87.9 high x 83.5mm deep
Weight	515g
Materials	Housing: White flame-retardant ABS

Application

Direct connection to the fire panel makes the ADR a Category A fire door retainer, as defined in BS7273-4 providing the panel has supporting BS 7273-4 category A functionality.

The addressable functionality allows panel cause & effect programming in complex buildings that facilitates evacuation whilst closing fire doors in alarmed areas. All doors or zones of doors can be closed automatically by the control panel or a dedicated input switch to enable a lockdown strategy in schools, colleges, courts & custodial.

Patented permanent magnet technology results in minimal current being required to hold doors open.

The ADR has twin LEDs to indicate Normal, Charging, Loop isolator activation and Device fault statuses.

Device Fault conditions include:

- Loss of protocol communication
- Insufficient loop power to charge

The unit is supplied with a manual release switch and is programmable to operate under failsafe conditions.

Installation

Decide on suitable mounting positions for the magnet and the keeper plate. The magnet should be at least 600 mm from the axis of the door hinge. The manual release switch should be easily accessible when the door is retained open.

Fit the door holder back box to the wall. This door holder can be used in semi-flush mounting or surface mounting applications. Check that any fixings used are strong enough to withstand the holding force of the door retainer.

Run the fire system loop wires (0.2mm² - 3.3mm²) through the back box and connect to the rear of the door retainer as per the Connections diagram. We recommend using cable glands (20mm) with fire cable in harsh environments. Fit the door holder to the back box with the screws supplied to a torque of 0.5Nm.

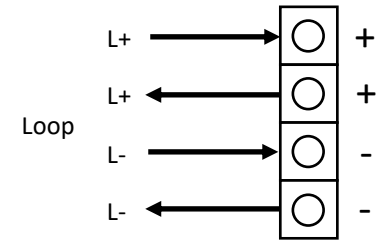

Check that the rubber ring is fitted in the base plate before fitting the keeper plate assembly loosely to the door. Adjust the angle to align with the magnet and tighten the mounting screws to lock the plate in place.

Do not use the door retainer until sufficient initialisation and self-check time has elapsed. This will take a minimum of 90 minutes and loop power should be connected at all times. The device will not actuate until the device has successfully completed the initialisation period.

Device Addressing

The 7-bit address is set using a DIL switch. Failsafe is enabled by switch 8.

Switch	1	2	3	4	5	6	7	8
Value	1	2	4	8	16	32	64	ON/ OFF
Use	Sets the address							Failsafe Enable

Please see BS7273-4 Code of practice regarding failsafe operation.

Example:



Please Note: Switch positions are opposite to other Apollo addressable products (1 is up, 0 is down)