

Fire detection and evacuation solutions that save lives.

Reach Wireless Heat Detector

Features

- Twin alarm, bi-colour LEDs for 360° visibility
- Programmable for rate-of-rise (A1R) or static temperature (BS)
- Bi-directional wireless communication
- Dual channel redundancy
- Ten year battery life

Description

The Reach Wireless Heat Detector is the latest in wireless detector technology. The detector is a fully intelligent device designed to give the best possible warning of a fire condition in locations where smoke detection technology is not suitable. The device is capable of being configured by the Reach XP95 Loop Interface Module as either rate-of-rise (A1R) or high temperature (BS) classification as specified in the product standard. The well-proven adaptive radio signal processing algorithms ensure the highest levels of life safety and system reliability are achieved.

Operating Principles

The Reach Wireless Heat Detector is flexible – offering either static (BS) or rate-of-rise (A1R) functionality.

Device Addressing

Device addressing is handled by the Reach XP95 Wireless Loop Interface Module. Devices are soft-addressed automatically when pairing with the Loop Interface and can be changed manually. Hard-addressing using XPERT cards are not required.

Communication

Reach Wireless Devices use ‘radio-frequency’ wireless communication to connect to the Loop-Interface.

The Loop-Interface translates the wireless communication into wired XP95 protocol communication, with each device addressable individually by the fire panel. Refer Loop-Interface datasheet for further information.

Maintenance and Service

Maintenance must be performed in accordance with all applicable standards. Clean the detector externally using a soft damp cloth. For full cleaning and recalibration detectors should be returned to Ampac.

Tamper detection

Reach Wireless devices contain an anti-tamper mechanism. In the event of removal from its base, it sends a tamper detection message to the Loop-Interface.

Tamper detection is not signaled visually by the device LED.



Specifications

Detection principle	Single NTC thermistor
Communication Range between Loop-Interface and Devices	100 m (in open space)
Field Device Radio Frequency Channel Pairs	22 pairs
Status LED	Green and Red
Radiated Power	14 dBm (25 mW)
Battery Type	2x VARTA CR123A Lithium 3 V, 1250mAh typical
Battery Lifespan	10 years in normal operation with good signal strength (no dropped messages)
Operating Temperature	-10°C to +55°C
Maximum Relative Humidity	95% (non-condensing)
IP Rating	40
Standards and approvals	EN54-5 Class P, EN54-25 NZS 4512 AS7240.5, AS7240.25
Dimensions	110 mm diameter x 70 mm height
Weight (including base and batteries)	190 g

Item Numbers

	AUS / NZ	International
Reach Heat Detector (white)	4106-5402	RW1000-400APO
Reach Heat Detector (black)	4106-5422	

All data is supplied subject to change without notice. Specifications are typical at 24 V, 25°C and 50% RH unless otherwise stated.

Fire detection and evacuation solutions that save lives.

Reach Wireless Heat Detector

Batteries

Reach Wireless devices are supplied with two CR123 batteries, battery A and B. The device switches periodically between the two batteries on a controlled sequence. For correct operation of the device, both batteries are required with adequate capacity reserves.

When battery A reaches a low power threshold, it will trigger a fault. This fault requires both batteries to be replaced in every instance as both batteries should be discharging equally.

When one (or both) batteries lack power, the Loop-Interface receives a low battery message and will signal this event on its in-built display, as well as relay the low battery message to the fire control panel. The battery fault will also be signaled by the device itself through its LED indicators if programmed (see table 1).

EMC Directive 2014/30/EU

Reach Wireless Heat Detector complies with the essential requirements of the EMC Directive 2014/30/EU, provided that it is used as described in this datasheet.

A copy of the Declaration of Conformity is available on request.

Conformity of the Reach Wireless Heat Detector with the EMC Directive does not confer compliance with the directive on any apparatus or systems connected to it.

Construction Products Regulation (EU) 305/2011

The Reach Wireless Heat Detector complies with the essential requirements of the Construction Products Regulation (EU) 305/2011

A copy of the Declaration of Performance is available on request.

Dimensions

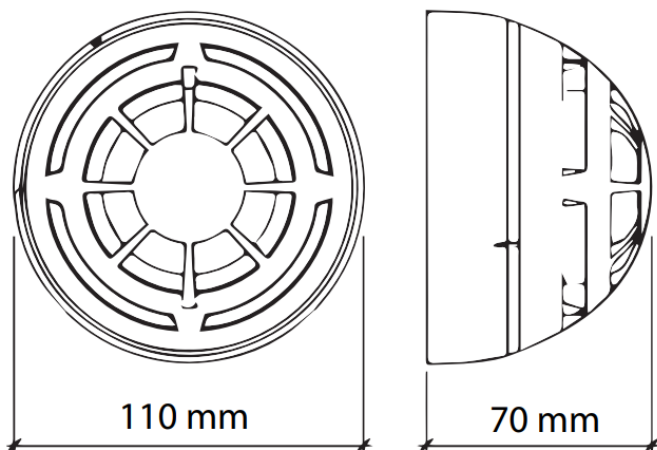

Status LED

It also includes a 360° LED indicator which illuminates red or green to indicate status conditions.

Table 1 - Reach Wireless Device Indication

Device Status	LED Indication
Power Up	Blinks green four times
Power Up (dip-switch ON)	Blinks red four times
Entering Wake-Up	Blinks alternatively green/red four times
Link Success	Blinks green four times, then repeats
Link Failure	Enters wake-up mode and signals 'Entering wake-up mode' following this failure
Normal Condition	LED off
Alarm	Red 1s, period 2s
Battery Faults	LED off
Tamper Fault	LED off
Replaced	Blinks amber two times

Base Compatibility

This device is compatible with the following bases:

Item Numbers

	Australia	International
Reach Standard Base (white)	4106-5400	
Reach Standard Base (black)	4106-5420	
Reach Sounder Base (white)	4107-8401	RW1300-110APO
Reach Sounder Base (black)	4107-8421	
Reach Sounder VAD Base White Flash	4107-8411	RW1300-210APO
Reach Sounder VAD Base Red Flash	4107-8412	RW1300-211APO

Approvals

