

Fire detection and evacuation solutions that save lives.

Reach Wireless Input Module

Features

- Fully supervised input
- Alarm & Fault condition monitored input
- Bi-directional wireless communication
- Dual channel redundancy
- Five year product warranty

Description

The Reach Wireless Input Module has a single fully monitored input circuit which allows simple integration of third-party equipment with the fire detection & alarm system. The Input Module adaptive radio signal processing algorithms ensure the highest levels of life safety and system reliability. The unit is powered entirely from its internal battery supply.

The Reach Wireless Input Module works on an ON/OFF logic and does not rely on any special and/or intelligent communication protocol for its operation (i.e. conventional call-points). Refer table below for wiring connection requirements.

Wiring Connections

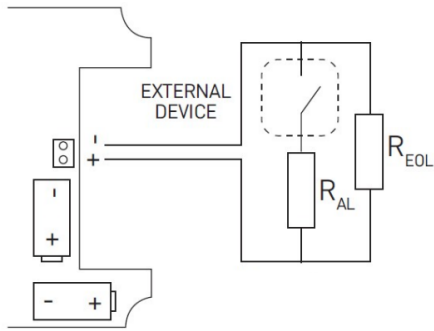

Specifications

Communication Range between Loop-Interface and Devices	100 m (in open space)
Field Device Radio Frequency Channel Pairs	22 pairs
Radiated Power	14 dBm (25 mW)
Battery Type	2x VARTA CR123A Lithium 3 V, 1250mAh typical
Battery Lifespan	10 years in normal operation with good signal strength (no dropped messages)
Operating Temperature	-10°C to +55°C
Maximum Relative Humidity (non-condensing)	95%
IP Rating	IP 65
Standards and approvals	EN54-18, EN54-25 AS7240.18, AS7240.25
Dimensions	136 mm diameter x 96 mm height x 57mm depth
Weight (including batteries)	270 g

All data is supplied subject to change without notice. Specifications are typical at 24 V, 25°C and 50% RH unless otherwise stated.

Reach Connection Requirements

Port	End of Line Impedance			Module Status	Notes
	Min	Typ	Max		
Input	6.5kΩ	10kΩ	14kΩ	Normal	-
	0	-	2.4kΩ	Fault	Short Circuit
	2.5kΩ	5kΩ	6.4kΩ	Alarm	Triggered by Contact
	14.2	-	+∞	Fault	Open Circuit
R _{EOL}	8kΩ	10kΩ	12kΩ	-	-
R _{AL}	5kΩ	5.6kΩ	6kΩ	-	-

Item Numbers

	Australia	International
Reach Input Module	4110-2103	RW1700-051APO

Fire detection and evacuation solutions that save lives.

Reach Wireless Input Module

Connection Requirements

The 10KΩ R resistor monitors whether the cable has been damaged or the connection is no longer available.

- The 5.6KΩ R resistor comes in and out of circuit depending on the state of the 3rd party device (alarm resistor).
- If you fail to install these resistors correctly the device will not operate as intended.
- Ensure the 3rd party device offers a voltage free relay switch.

Note: install a properly fire rated cable (according to national code of practice) between the third-party device and the input module.

Status LED

The LED indicator's messages are used only during installation and servicing. LED indicator is inactive when the front cover is in place for saving up battery charge (and due to the fact that normally the LED is hidden by the front cover).

Reach Device Status & LED Indication

Device Status	LED Indication
Power Up	Blinks green four times
Power Up (dip-switch ON)	Blinks red four times
Entering Wake-Up	Blinks alternatively green/red four times
Link Success	Blinks green four times, then repeats
Link Failure	Enters wake-up mode and signals 'Entering wake-up mode' following this failure
Normal Condition	LED off
Alarm	Red 1s, period 2s
Battery Faults	LED off
Tamper Fault	LED off
Replaced	Blinks amber two times

Approvals



Device Addressing

Device addressing is handled by the Reach Wireless Loop Interface device.

Devices are soft-addressed automatically when pairing with the Loop Interface and can be changed manually. Hard-addressing using XPERT cards are not required.

Communication

Reach Wireless Devices use 'radio-frequency' wireless communication to connect to the Loop-Interface.

The Loop-Interface translates the wireless communication into wired Apollo protocol communication, with each device addressable individually by the fire panel. Refer Loop Interface datasheet for further information.

Tamper detection

Reach Wireless devices contain an anti-tamper mechanism. In the event of removal from its base, it sends a tamper detection message to the Loop Interface.

Tamper detection is not signaled visually by the device LED.

EMC Directive 2014/30/EU

Reach Wireless Input Module complies with the essential requirements of the EMC Directive 2014/30/EU, provided that it is used as described in this datasheet.

A copy of the Declaration of Conformity is available on request.

Construction Products Regulation (EU) 305/2011

The Reach Wireless Input Module complies with the essential requirements of the Construction Products Regulation (EU) 305/2011.

A copy of the Declaration of Performance is available on request.

Dimensions

