

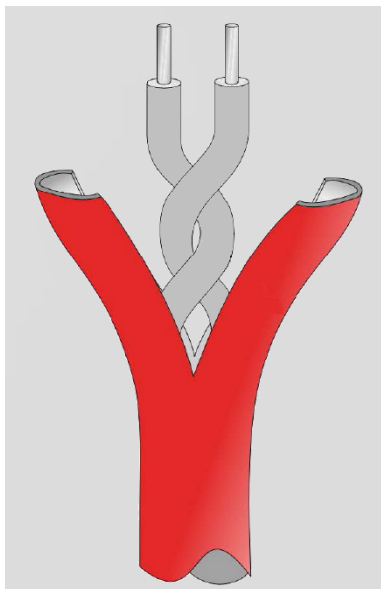

Fire detection and evacuation solutions that save lives.



ProReact Digital Fixed Temperature Linear Heat Detection Cable

MAN3203

Content

1	Important Guidelines	3
2	Introduction	4
	Digital Interface Monitor Module	4
	Detection Monitor Module	4
	Electrical Specifications	4
	Environmental Specifications.....	4
3	Technical Specifications	5
	Technical Data	5
	Mechanical Specifications.....	5
4	Typical System Configurations	6
	Conventional Fire Alarm Systems	6
	Addressable Fire Alarm Systems	6
	Typical Wiring Connection	6
	Digital Interface Monitor Module	7
5	Installation Specifications	8
	Leader Cable.....	8
	Detection Cable	8
6	Installation Hardware	8
7	Area Protection	9
8	Low Temperature Installation Considerations	9
9	Testing and Verification	9
10	Splicing	10
11	Chemical Resistance Chart	10
12	ProReact Digital Linear Heat Detection Product Range	11

1 Important Guidelines

Please read this instruction leaflet thoroughly before commencing installation.

- ✓ Install the linear heat detection cable accordingly to meet local and country installation requirements.
- ✓ ProReact linear heat detection cable must be installed in accordance with NFPA 70 & 72, NEC 760 (National Electric Code) and Authorities Having Jurisdiction.
- ✓ Support the detection cable at 1m (3ft) to 1.5m (5ft) intervals.
- ✓ Test the detection cable before installation using a multimeter.
- ✓ Ensure the maximum ambient temperature rating of the detection cable will not be exceeded during storage or normal operating conditions.
- ✓ Ensure the detection cable is spaced at less than or equal to the maximum approved spacing.
- ✓ Ensure the detection cable is not in contact with any material which may conduct heat onto the cable directly.
- ✓ A silicone pad should be placed between the fixing clip and heat sensing cable.
- ✓ Ensure any cable glands used are tightened to form a secure and moisture proof seal around the detection cable.

- ⚠ Avoid allowing the detection cable to come in contact with any material which acts as a heat sink. This may delay the activation of the cable in alarm situations.
- ⚠ Do not exceed the maximum operating voltage of the detection cable (48Vdc).
- ⚠ Do not connect two lengths of detection cable which have different action temperatures.
- ⚠ Do not paint the detection cable.
- ⚠ Do not place the detection cable under excessive tension.
- ⚠ Do not bend the detection cable at right angles. The minimum bend radius is 2" or 50mm.
- ⚠ Avoid subjecting the detection cable to mechanical damage which could result in false activation.
- ⚠ Avoid laying the detection cable in areas where heavy traffic may result in the cable being crushed.

2 Introduction

The ProReact Digital Linear Heat Detection Cable uses fixed temperature detection technology to provide an easy method for sensing changes in temperature levels. The cable can offer alternative overheating protection in a vast range of applications and environments, from tunnels, cable trays, warehousing to sensing changes in temperature within escalators and other applications where many risks of fire are hidden from view.

The digital linear heat detection cable can be directly connected to a single zone of conventional fire alarm control panel, or, using an addressable zone/switch monitor, the digital linear heat detection cable can easily be interfaced to an addressable loop.

Digital linear heat detection cable is comprised of a pair of twisted low resistance, tri-metallic conductors, sheathed in advanced temperature sensitive polymers. When the cable reaches the required temperature the two twisted cores will fuse together, with a fire triggering resistor attached to the input interface and a single core of linear heat cable to activate an alarm at the main fire panel (see schematic).

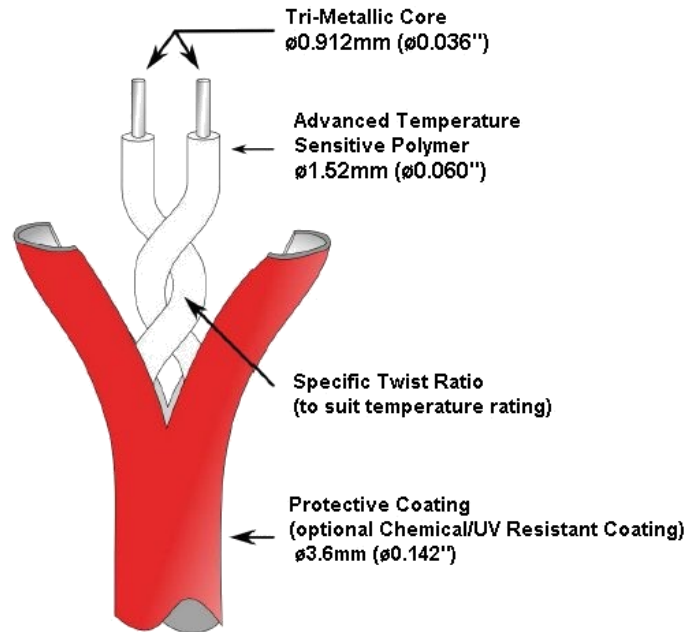

Figure 1: Fixed Temperature Linear Heat Detection Cable Construction

Digital Interface Monitor Module

A UL864 10th edition approved Digital Interface Monitor Module is available and provides additional benefits when used with the ProReact Digital LHD cable. It can simultaneously monitor up to two zones of LHD cable and has separate fault and alarm outputs for each zone. A built in display shows the state of each zone, including the distance in meters and feet to the alarm point if an alarm is triggered. It also includes an RS-485 Modbus RTU output for integration with a PLC or SCADA system.

Detection Temperatures

- 68°C (155°F)
- 78°C (172°F)
- 88°C (190°F)
- 105°C (221°F)
- 185°C (365°F)

Electrical Specifications

Operating Voltage Range	0-30Vac, 0-42Vdc
Resistance	Approx 100/km (30.4/kft) per leg
Velocity of Propagation	Approx 55%
Capacitance	88 – 150pF/m
Inductance	540 – 1050nH/m

Environmental Specifications

Maximum ambient temperature	
68°C, 78°C	45°C (113°F)
105°C, 88°C	65°C (149°F)
185°C	125°C (257°F)
Humidity	0% to 100% RH
Minimum Operating Temperature	-40°C (-40°F)

3 Technical Specifications

Technical Data

Construction	Overall insulated, twisted pair of tri-metallic cores
Insulation	1kV tested protective outer coat
Additional Insulation Options	Nylon, Polypropylene or stainless steel braiding
Approvals	CE marked, RoHS compliant, FM, UL, GOSTR
Maximum Zone Length	3,000m (10,000ft)
Wire Overall Diameter	3.60mm to 5.08mm (0.142" to 0.200")
Minimum bend radius	50 mm (2")
Ambient Temperature Range: (Dependent upon action temperature)	-40°C – 125°C (-40°F – 257°F)
Electrical	
Max Voltage Rating	30Vac, 42Vdc
Resistance	~100/km (29/kft) per leg
Velocity of Propagation	~55%
Capacitance	88 – 150 pF/m (26 – 45 pF/ft)
Inductance	540 – 1050 nH/m (165 – 320 nH/ft)

Mechanical Specifications

Material	Overall insulated, twisted pair of tri-metallic cores
Colour	(additional nylon coating is always black)
68°C, 78°C	Red
88°C, 105°C	White
185°C	Red
Diameter (all)	
PVC Coating	3.60mm +/- 0.12mm (0.142" +/- 0.005")
... with additional Polypropylene coating	4.44mm +/- 0.12mm (0.175" +/- 0.005")
... with additional Nylon coating	4.50mm +/- 0.12mm (0.177" +/- 0.005")
... with additional Stainless Steel Braid	4.10mm +/- 0.12mm (0.161" +/- 0.005")
... with additional Nylon Coating & Stainless Steel Braid	5.08mm +/- 0.12mm (0.200" +/- 0.005")

4 Typical System Configurations

Conventional Fire Alarm Systems

ProReact Linear Heat Detection (LHD) cable should be connected to the initiating device circuit on a conventional fire alarm control panel. Leader cable may be used between the beginning of the LHD cable and the fire alarm control panel if the area requiring protection is some distance away from the control panel. A junction box should be used to connect the leader cable to the linear heat detection cable to ensure a secure, waterproof electrical connection.

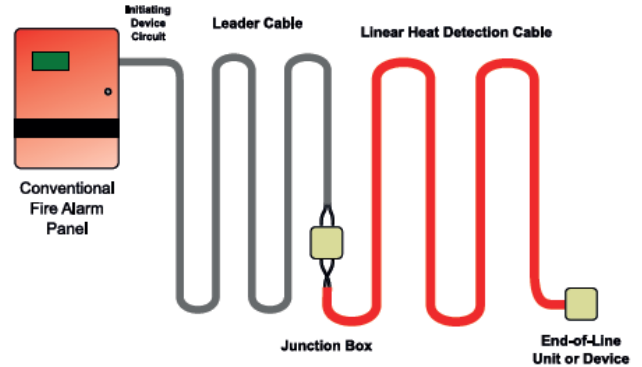

Figure 1: Typical Wiring Configuration Conventional System

Addressable Fire Alarm Systems

When used as part of an addressable system, ProReact Linear Heat Detection cable should be connected onto the addressable loop using a switch or zone monitor. External power is not required for the Linear Heat Detection cable. Leader cable may be used between the beginning of the LHD cable and the addressable switch or zone monitor if the area requiring protection is some distance away. A junction box should be used to connect the leader cable to the linear heat detection cable to ensure a secure, waterproof electrical connection.

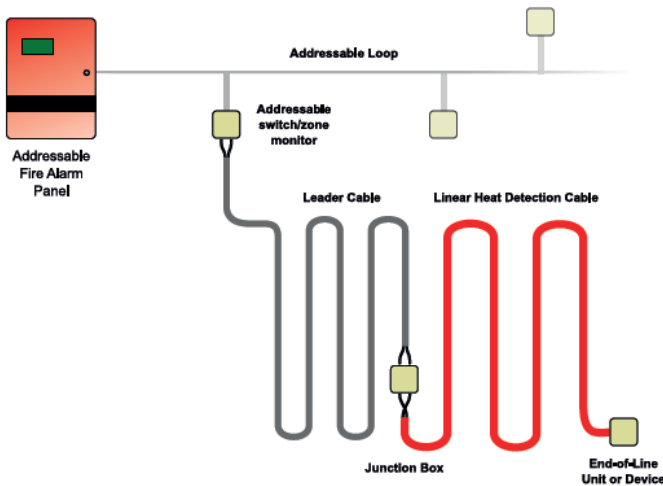
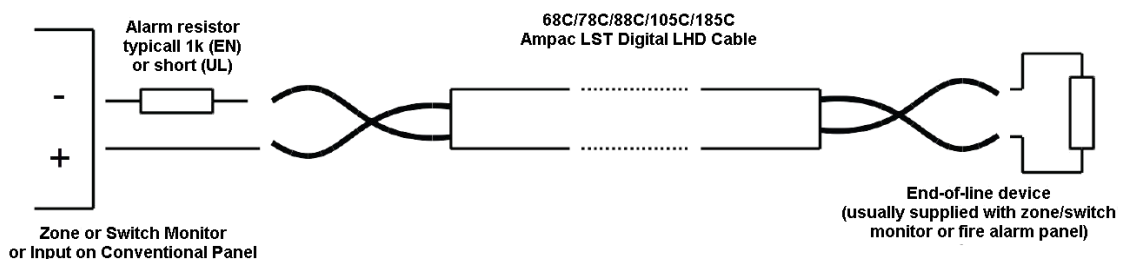

Figure 2: Typical Wiring Configuration Addressable System

Typical Wiring Connection

- Open circuit on LHD cable = fault.
- Overheat/Fire on LHD cable = alarm.



Digital Interface Monitor Module

A Digital Interface Monitor Module (ProReact—DiMM) is available for use with ProReact Digital Linear Heat Detection Cable. The DiMM can simultaneously monitor up to two zones of digital LHD cable and provides additional benefits to using LHD cable, including:

- Ability to provide pre-alarm and alarm signal to a fire alarm panel (using two LHD cables with different action temperatures)
- Fail-safe alarm activation (using two LHD cables with the same action temperature, both must alarm for the fire alarm system to trigger an alarm)
- RS-485 Modbus RTU output for connection to a PLC or SCADA system.
- The DiMM has a built in display which shows the state of each zone and automatically displays the distance in metres and feet to the alarm point if an alarm is triggered.

Leader cable between the DiMM and the Linear Heat Detection cable can be calibrated out at the commissioning stage. Refer to the DiMM manual for more information.

Mapping of the system is important when using a Digital interface Monitor Module. During installation draw a map to associate distances along the detection cable to locations within a building/warehouse etc. This will aid in locating the area requiring attention in an alarm condition.

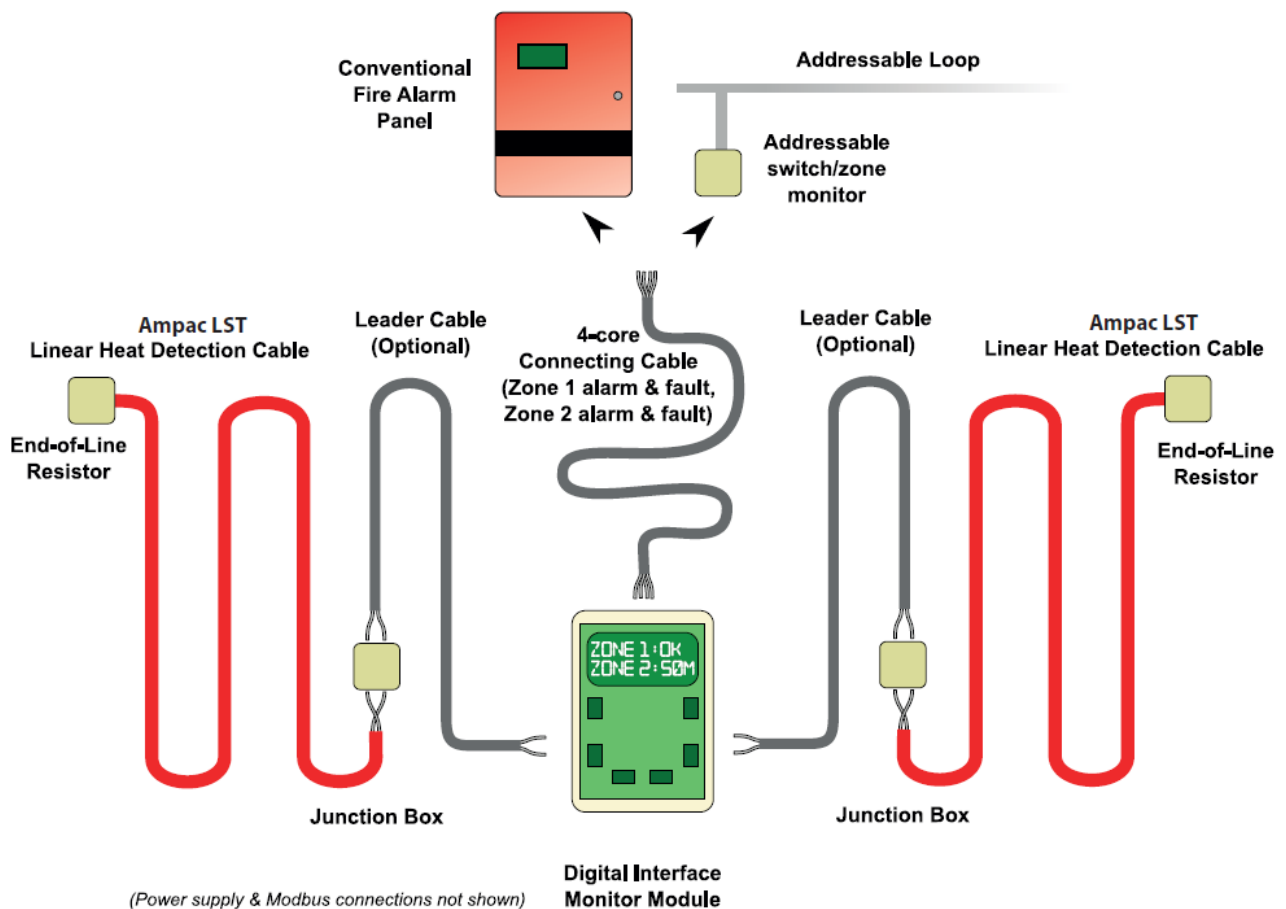

Figure 3: Typical Wiring Configuration with Digital Interface Monitoring Module

5 Installation Specifications

Leader Cable

An approved type of leader cable, preferably Fire Rated cable, should be used between the fire alarm control panel or addressable switch/zone monitor and the Linear Heat Detection cable. A secure waterproof (IP65 or greater) junction box must be used to connect the leader cable to the detection cable. It is recommended that leader cable with the following minimum cross sectional area (CSA) per conductor is used when using the maximum length of detection cable. Consult with the authority having jurisdiction and the fire alarm control panel manufacturer for further information.

Recommended Maximum Leader Cable Length and CSA for copper conductors (with maximum length of Linear Heat Detection Cable 3km/10kft)

- 0.8 mm² (18AWG) — Upto 2,500m (8,200ft)
- 1.3 mm² (16AWG) — Upto 3,500m (11,500ft)
- 2.0 mm² (14AWG) — Upto 6,000m (20,000ft)
- 3.3 mm² (12AWG) — Upto 9,500m (31,000ft)

Detection Cable

A very important factor in determining which rating of fixed temperature linear heat detection (LHD) cable to use is the maximum ambient temperature the cable will be exposed to. To provide the fastest alarm response but lowest possibility for false alarms the detection cable with the lowest action temperature above the maximum ambient temperature should be chosen. For example, if the maximum ambient temperature is determined to be 55°C (131°F), a detection cable with an action temperature of 88°C (190°F) should be chosen (if the fastest possible response time is required).

Maximum Ambient Temperature	Available Action Temperatures
Up to 45°C (113°F)	68°C (155°F), 78°C (172°F)
Up to 65°C (149°F)	88°C (190°F), 105°C (221°F)
Up to 125°C (257°F)	185°C (365°F)

6 Installation Hardware

There are many applications where Linear Heat Detection cable is used to provide protection. Please refer to the ProReact Linear Heat Detection applications Guide for more information on the types of fittings which should be used. The list is not exhaustive, however, any fitting not mentioned in the Application Guide which may be used should be evaluated to ensure it is fit for purpose. Consult the authority having jurisdiction for more information.

The linear heat detection cable should be adequately supported to prevent sagging. Ideally cable supports should be placed every 1m (3ft) and no more than 1.5m (5ft) apart. It may be necessary to place more supports around corners and other transition areas.

Care should be taken when mounting the cable in clips (or equivalent) that they are not done so tight as to crush the cable. The detection cable should be held firmly without deformation. Avoid placing excessive tension in the cable, no greater than 50N. Ensure also that the minimum bend radius is observed at all times – 50mm (2").

It is of particular importance to use a silicone pad between the heat sensing cable and the fixing clip if the metal clip is exposed to the sun or attached to a piece of equipment which may get hot and transfer the heat to the cable.

Where possible, it is preferable to install the linear heat detection cable in one continuous run of cable with as few splices as possible.

When pulling the detection cable from a reel, a reel stand must

be used. Do not pull the cable off the reel stationary as this will twist and damage the cable. A guide wire may be required for installations where the cable at the recommended spacing is not practical. Ensure the diameter or gauge of the guide wire is adequate for the distance which is being spanned. Commercially available stainless steel wire with a diameter of approximately 2mm is suitable for use as a guide wire.

Connections into junction boxes and other enclosures must use strain relief connectors which provide dust and moisture protection (IP65 or greater protection). The standard diameter of detection cable is 3.6mm (0.142") to 5.08mm (0.200"). Suitable cable glands are shown opposite which fit an M12 standard knockout.



Figure 4: Typical Cable Glands for connection Linear Heat Detection cable into an enclosure

7 Area Protection

ProReact cable is suitable for broad or wide area detection of overheat or fire conditions, e.g warehouses etc. The LHD cable should be installed with a minimum distance between the cable and the ceiling of 20mm to allow hot gases rising from an event to trigger the detection cable.

Maximum support spacings should be followed (see illustration right) and the cable securely attached to the ceiling or beams. For ceilings up to 9m (30ft) in height maximum spacing between runs should be as in the table below. For ceilings over 9m (30ft) in height the spacings should be halved. The corresponding value in the table below should be halved for spacing between walls/partitions etc. and a run of detection cable.

ProReact LHD Action Temperature	UL/cUL	FM
68°C (155°F), 78°C (172°F), 88°C (190°F),	10m (35ft)	9m (30ft)
105°C (221°F),	10m (35ft)	7.5m (25ft)

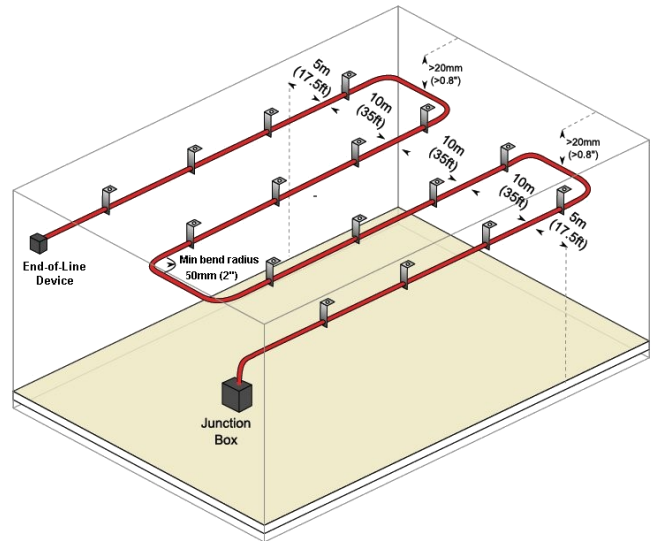

8 Low Temperature Installation considerations

Fixed temperature Linear Heat Detection cable is suitable for use in ambients down to -40°C (-40°F). Such conditions occur in cold storage freezer warehouses and outdoors for example. Take special care when installing LHD cable in low ambients or for use in low temperature conditions careful consideration of the conditions and environment should be undertaken.

Do not install the LHD cable when the ambient temperature is below 10°C (14°F). The materials within the cable will become less flexible and are more prone to damage. If the ambient temperature is likely to drop significantly after installing the cable take into account the linear shrinkage of the cable when attaching support brackets. The cable can shrink in length by 12% at -40°C (-40°F).

A silicone pad should be placed around the cable before

clipping into the support bracket. This prevents damage to the cable and reduces the heat sink effect of the clip.

The minimum bend radius of the detection cable should be increased to 100mm (4") to account for the reduced flexibility. The maximum distance between support brackets should be no more than 1m (3ft) and it is important to support the cable close to either side of any bend. Ensure any junction boxes other enclosures are waterproof and suitable for the expected operating temperatures.

9 Testing and Verification

Routine maintenance and checking should be carried out to ensure the Linear Heat Detection cable will function as expected and has not been damaged etc.

A visual inspection should be performed to ensure all support brackets and other aspects of the physical installation are suitable. The cable should also be visually checked for damage to the outer or inner insulation. Check to make sure the silicone pads are correctly installed around the cable in the clips.

Any joints which have been made should be checked to make sure they are secure and the sealant or insulating tape has not begun to come off. New tape should be applied if necessary. Electrical tests should be carried out to determine the circuit created by the conductors is working. Remove the conductors from the fire alarm control panel or addressable switch monitor and measuring the resistance across them. The resulting value should equal the end-of-line resistance plus approximately 100/km for each leg. To test circuit with fire alarm control panel or addressable switch monitor re-attach the LHD cable.

Shorting out the End of Line device should put the system into

alarm. Disconnecting either leg from the end of line device should put the system into fault.

Functional testing

Fixed Temperature Linear Heat Detection Cable is non-restorable – any section which has alarmed must be cut out and replaced. Therefore functional testing of the installed cable will not normally be carried out.

However, if required, any LHD cable leftover after installation can be used to periodically perform a functional test. A 1m (3ft) section of cable should be attached between the end of the LHD cable run and the end-of-line device.

Using a suitable device heat the test length of detection cable up. Once the action temperature (including any tolerances) has been reached the system should alarm. Ensure the test length is removed before placing the system back into normal operation.

10 Splicing

If the fixed temperature linear heat detection cable gets damaged or has triggered due to an overheat condition, the section can be removed and a new section spliced in its place.

Care should be taken during splicing to ensure the two core conductors do not come into contact with each other at any point and the final spliced joint is secure and made waterproof. A junction box can be used if required however it is also acceptable to splice together two ends of detection cable using a connection box and seal the splice using sealant tape (see figure 11).



When replacing a section of the detection cable due to an overheat condition having occurred, the section including at least 3m (10ft) either side of the known event should be replaced.

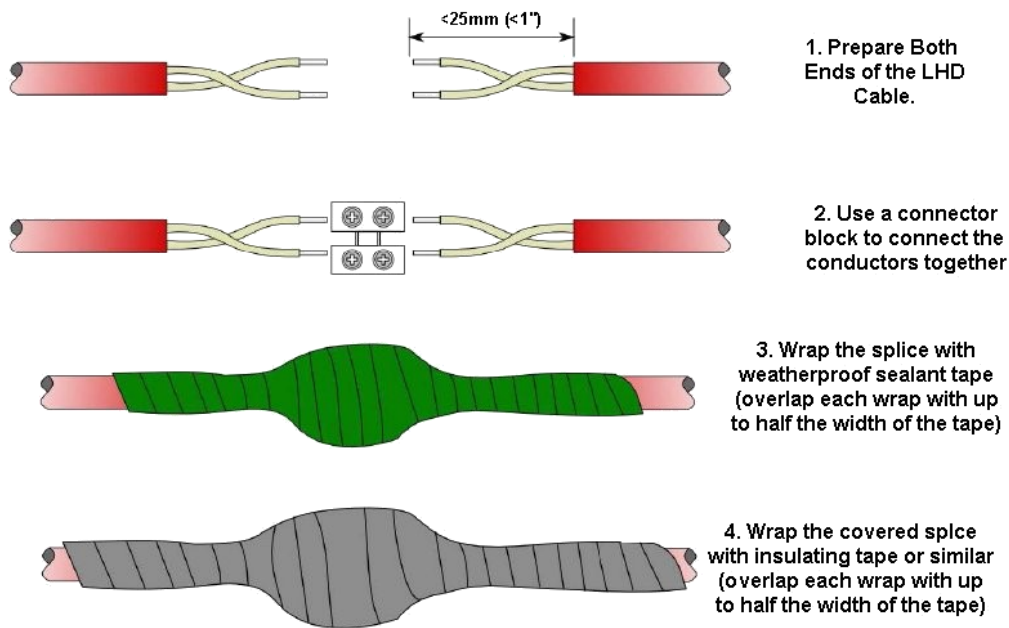

Figure 11: Splicing together joints in LHD cable

11 Chemical Resistant Chart

Chemical	PVC	Nylon	Polypropylene
Ammonia, Liquid			
Butane			
Copper Nitrate			
Fuel Oils			
Gasoline			
Hydrofluoric Acid			
Kersene			
Diesel Fuel			
Acetic Acid			

12 ProReact Digital Linear Heat Detection Product Range

Part No (4114-)	Description	ALL WEIGHT IN KG UNLESS OTHERWISE STATED											
		100m Reel			200m Reel			500m Reel			1000m Reel		
		Net Wt	Gross Wt	Dims (mm)	Net Wt	Gross Wt	Dims (mm)	Net Wt	Gross Wt	Dims (mm)	Net Wt	Gross Wt	Dims (mm)
1001	ProReact Digital LHD 68°C PVC	2.04	2.69		4.08	4.73		10.20	13.00		20.41	23.55	
1101	ProReact Digital LHD 68°C Nylon Outer Sheath	2.64	3.29	ø300 x 100	5.28	5.93	ø300 x 100	13.21	16.01	ø430 x 135	26.42	29.56	ø430 x 250
1201	ProReact Digital LHD 68°C Polypropylene Outer Sheath	2.55	3.20		5.10	5.75		12.75	15.55		25.49	28.63	
1301	ProReact Digital LHD 68°C Stainless Steel Outer Braid on PVC	3.29	3.94		6.58	7.23		16.44	19.24		NA	NA	
1002	ProReact Digital LHD 78°C PVC	2.04	2.69		4.08	4.73		10.20	13.00		20.41	23.55	
1102	ProReact Digital LHD 78°C Nylon Outer Sheath	2.64	3.29	ø300 x 100	5.28	5.93	ø300 x 100	13.21	16.01	ø430 x 135	26.42	29.56	ø430 x 250
1202	ProReact Digital LHD 78°C Polypropylene Outer Sheath	2.55	3.20		5.10	5.75		12.75	15.55		25.49	28.63	
1302	ProReact Digital LHD 78°C Steel Outer Braid on PVC	3.29	3.94		6.58	7.23		16.44	19.24		NA	NA	
1003	ProReact Digital LHD 88°C PVC	2.04	2.69		4.08	4.73		10.19	12.99		20.38	23.52	
1103	ProReact Digital LHD 88°C Nylon Outer Sheath	2.66	3.31	ø300 x 100	5.31	5.96	ø300 x 100	13.28	16.08	ø430 x 135	26.56	29.70	ø430 x 250
1203	ProReact Digital LHD 88°C Polypropylene Outer Sheath	2.50	3.15		4.99	5.64		12.48	15.28		24.97	28.11	
1303	ProReact Digital LHD 88°C Stainless Steel Outer Braid on PVC	3.29	3.94		6.57	7.22		16.43	19.23		NA	NA	
1004	ProReact Digital LHD 105°C PVC	1.88	2.53		3.76	4.41		9.41	12.21		18.81	21.95	
1104	ProReact Digital LHD 105°C Nylon Outer Sheath	2.56	3.21	ø300 x 100	5.12	5.77	ø300 x 100	12.81	15.61	ø430 x 135	25.61	28.75	ø430 x 250
1204	ProReact Digital LHD 105°C Polypropylene Outer Sheath	2.46	3.11		4.92	5.57		12.29	15.09		24.58	27.72	
1304	ProReact Digital LHD 105°C Stainless Steel Outer Braid on PVC	3.13	3.78		6.26	6.91		15.64	18.44		NA	NA	
1105	ProReact Digital LHD 185°C Nylon Outer Sheath	1.79	2.44	ø300 x 100	3.59	4.24	ø300 x 100	8.97	11.77	ø430 x 135	17.94	21.08	ø430 x 250
1305	ProReact Digital LHD 185°C Stainless Steel Outer Braid on Nylon	3.04	3.69		6.08	6.73		15.21	18.01		NA	NA	
1950	Digital Location Control Unit (Metric Gland Knockouts)	653g		180x 130x78									
1951	Digital Interface Monitor Module (DiMM)	673g		180x 120x61									

UNCONTROLLED DOCUMENT

NOTE: Due to AMPAC's commitment to continuous improvement specifications may change without notice.