

Fire detection and evacuation solutions that save lives.

## Flush or Surface Mount Door Holder – Metal Case

### Features

- 200N Robust Metal Case
- 24V DC or 230V AC Supply Voltage
- 200N (20kg) Holding Force
- Zero Residual Force
- Integral Release Switch
- Adjustable Swivel Keeper Plate
- Floor Mount Bracket (optional)

### Description

The Flush Mount Door Holder is built around a robust fascia plate for flush mounting on a back box. The Surface Mount unit is supplied with a back box incorporating 20mm knockouts. Designed to allow doors to be held open under normal conditions and released during a fire alarm condition, the Door Holders are simple to install and commission and are suited to a wide range of applications including:

- Theatres and Cinemas
- Hospitals and Nursing Homes
- Schools, Colleges and Universities
- Manufacturing and Office Buildings

The Flush or Surface Mount Door Holders are 24Vdc or 230Vac powered and incorporate a built in switch to enable manual release of the door during emergencies or for maintenance purposes. The 230Vac unit includes a filter for EMC emissions. Internal diodes dissipate any “back EMF” on switch-off reducing wear at the control unit.

Each Door Holder is supplied as standard with an adjustable keeper plate which should be mounted on the door. An extensive range of alternative Keeper Plates are also available for special applications.

### Assembly

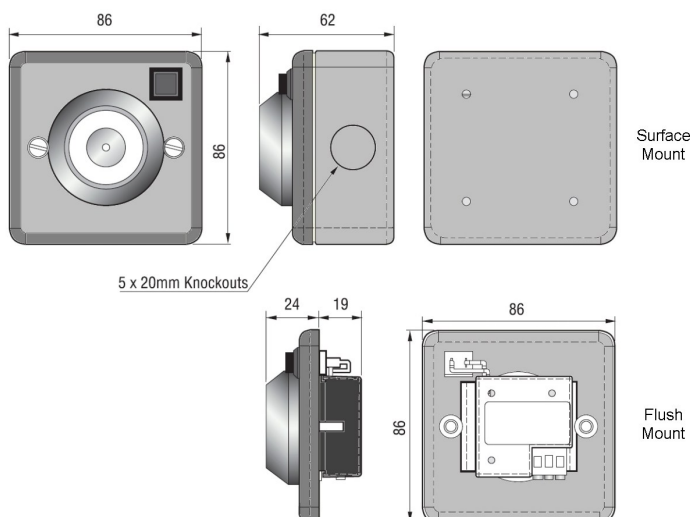

*Flush Mount Door Holder*

### Item Numbers

4101-3001	Flush Mount 200N 24Vdc Door Holder
4101-3005	Flush Mount 200N 230Vac Door Holder
4101-1004	Surface Mount 200N 24Vdc Steel Case
4101-1005	Surface Mount 200N 230Vac Steel Case
4101-6001	Floor Mount Bracket
4101-6004	Adjustable Keep Plate (spare)

### Specifications

4101-	3001/1004	3005/1005
Operating Voltage	24V dc	230V ac
Current	50mA	12mA
Holding Force	200N	
Newtons	200N	
Kilograms	20.4kg	
Residual Force	Zero	
Dimensions (mm)		
Flush Mount	86 W x 86 H x 43 D	
Surface Mount	86 W x 86 H x 62 D	
Manual Release	Yes	
Keeper Adjustment	+/- 30°	
Operating Temp.	-10° to +50°C	
IP rating	IP51	
Finish	Nickel Coated / Painted White	
Approval	EN1155	