



Certificate of Conformity

| Certificate num. | Registration date | Version | Valid until | |
|-------------------|-------------------|--------------|---------------------------|-------------|
| afp - 2802 | 15-Feb-2013 | Number 15 | Issue date 15-Apr-2026 | 30-Apr-2027 |

Page 1 of 5

Product designation

Ampac, LoopSense, fire alarm control panel

(Refer to the Schedule/enclosures for further specified details)

Agent/distributor

Ampac Pty Limited
7 Ledger Road, BALCATTA, WA, AUSTRALIA, 6021

Registrant

Ampac Pty Limited
7 Ledger Road, BALCATTA, WA, AUSTRALIA, 6021

Producer

Ampac Pty Limited
7 Ledger Road, BALCATTA, WA, AUSTRALIA, 6021

Conformance criteria and evaluation

The Ampac, LoopSense, fire alarm control panel has been evaluated and verified as conforming with the relevant requirements of the following criteria.

1. Australian Standard AS 7240.2-2004, 'Fire detection and alarm systems - Part 2: Control and indicating equipment (ISO 7240-2:2003, MOD)'.
2. Australian Standard AS 7240.4-2004, 'Fire detection and alarm systems - Part 4: Power supply equipment (ISO 7240-4:2003, MOD)'.
3. Australian Standard AS 4428.3-2010, 'Fire detection, warning, control and intercom systems - Control and indicating equipment - Fire brigade panel'.

Limitations/conditions of conformance

Limitations/conditions of conformance, where identified on this certificate, are derived from qualifications from evaluation(s) for conformity and/or other related technical documentation. All details with respect to design, assembly and installation instructions and restrictions should be checked against the producer's current technical manual/data sheets and the requirements of the Authority having Jurisdiction.

Specified limitations/conditions, determined from the evaluation for conformity, include the following.

- i. The equipment is installed where environmental conditions are within the manufacturer's specified range.
- ii. The equipment is installed and maintained in environments as recommended by the manufacturer.
- iii. Compatibility of this equipment with new or existing actuating devices should be verified prior to installation.

Issued by

Kai Loh
Executive Officer – ActivFire Scheme



Schedule to Certificate of Conformity

| Certificate num. | Registration date | Version | Valid until | |
|-------------------|-------------------|--------------|---------------------------|-------------|
| afp - 2802 | 15-Feb-2013 | Number 15 | Issue date 15-Apr-2026 | 30-Apr-2027 |

Producer's description

The Ampac, LoopSense, fire alarm control panel is control and indicating equipment (c.i.e.) forms the central part of a fire detection and alarm system. The c.i.e. contains an integrated fire brigade panel (f.b.p)

The Smart Terminal has facilities to be used as a remote f.b.p., or mimic panel. It is designed for use as supplementary equipment to the fire alarm control panel.

The purpose of the Ampac, LoopSense, fire alarm control panel is to monitor changes in inputs, report those changes and update selected outputs as programmed.

The equipment processes changes in inputs such as fire, fault, pre-alarm, emergency, security, user, system and transparent and has a built-in menu structure to view its status, perform operational tests, and modify the panel's configuration and programming.

System Components

Figure 1 provides illustration of the main components for the system and the connectivity between them.

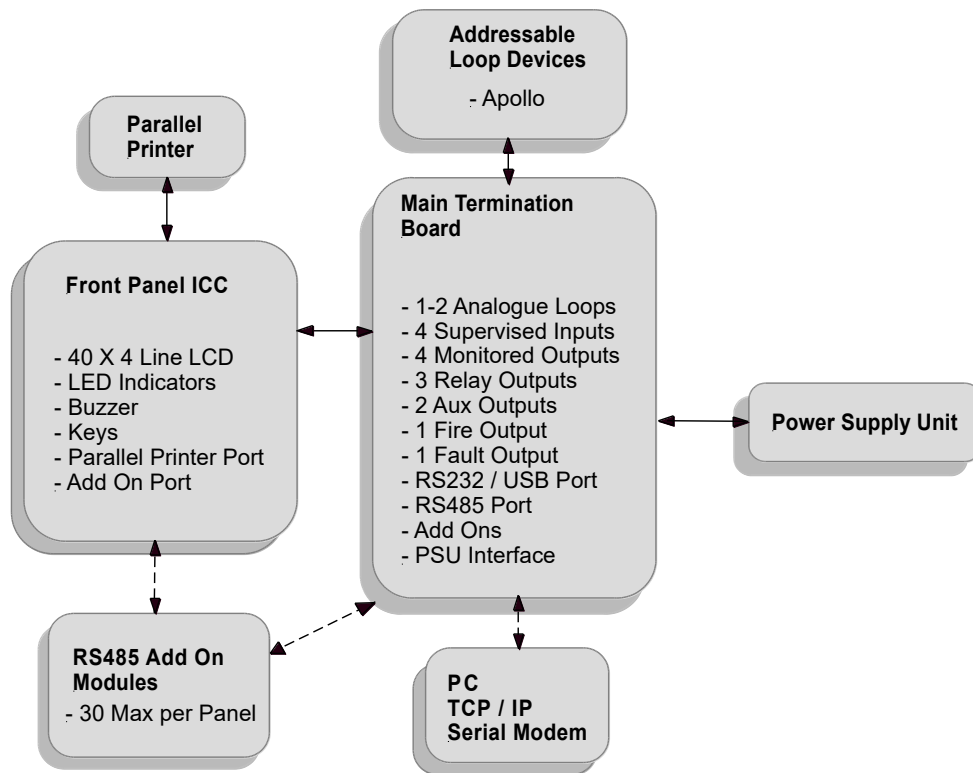

Figure 1: The LoopSense Concept

Overview & Key Features

LoopSense is a 1 or 2 loop Intelligent Analogue / Addressable FACP capable of supporting Apollo protocol - 126 detectors per loop

LoopMaster is software used to configure the operational parameters of the *LoopSense* FACP and any Add-ons used on the system.

Schedule to Certificate of Conformity

| Certificate num. | Registration date | Version | Valid until | |
|-------------------|-------------------|--------------|---------------------------|-------------|
| afp - 2802 | 15-Feb-2013 | Number 15 | Issue date 15-Apr-2026 | 30-Apr-2027 |

Page 3 of 5

Features

- The front panel 8 line LCD, navigation keys ◀ ▶ ▲ ▼, alpha numeric keypad and the Menu/Enter keys allow the *LoopSense* to be programmed “on site”. The same LCD and keys are also used for panel operation and interrogation
- 4 supervised outputs
- 4 supervised input connections
- 3 relay outputs
- System expansion capabilities / options
- Password entry
- A range of secure user functions, including the ability to disable/enable system functions
- Flush or surface mountable enclosure. A surround is required for the metal cabinet.
- Controls with tactile and audible feedback of operation
- All terminals cater for 2.5mm cables

Analogue Loops

Each FACP supports up to 2 addressable loops. Expansion beyond one loop is enabled by plugging in the “Loop Activation Key” into CN7 and activating it within *LoopMaster*. The number of loops enabled and the protocol (Apollo) used is selectable in the configuration software and is site configurable.

Analogue Loop Cabling Criteria

Two core cable with a minimum cable size is 0.75 mm² is recommended. The maximum loop resistance is 50 ohms and the maximum loop distance is 2 km.

The loops consist of positive and common conductors and are able to source up to 500 mA of current. The loops;

- operate in single ended and redundant configurations; and
- are monitored for over current and short circuit in single ended mode; and
- monitored for over current, short circuit and open circuit in the redundant mode.

Notes:

1. A loop test function is available via the FACP user interface.
2. Zone Indicators; 1 – 16 for a single loop configuration and 32 for a 2 loop configuration

FACP Main Termination Board Inputs & Outputs

1 to 4 *Supervised Inputs* TB1 6 to 9: Programmable Digital inputs compatible with voltage free type outputs supervised for open, short and earth faults. Default input configurations are I/P 1 = FIRE (MCP), I/P 2 = Door Switch, I/P 3 = Fault, I/P 4 = Reset. If a fire alarm routing equipment (FARE) I/P is required this I/P 4's configuration would be changed to FARE.

1 to 4 *Supervised Outputs* TB3: Programmable Supervised switched 24 Vdc output sourcing up to 500mA and supervised for short, open and earth faults.

1 to 3 *Relay Outputs* TB4: Programmable Voltage free relay contacts. Consists of NC, C and NO contacts.

1 to 2 *Auxiliary 24 Vdc Outputs* TB1 3 and 4 (Continuous) & TB5- Programmable (Continuous / Re-settable), both supervised for over current, switched 24 Vdc output sourcing up to 500 mA.

1 *Fire Output* Out 1 TB6/2: Supervised low current (limited to 30 mA), activated when there is a fire condition present on the FACP.

1 *Fault Output* Out 2 TB6/3: Supervised low current (limited to 30 mA), activated when there is a fault condition present on the FACP.

Schedule to Certificate of Conformity

| | | | | |
|-------------------|-------------------|--------------|---------------------------|-------------|
| Certificate num. | Registration date | Version | Valid until | |
| afp - 2802 | 15-Feb-2013 | Number 15 | Issue date 15-Apr-2026 | 30-Apr-2027 |

Technical specification

The following details are a representative extract of the technical specification for the Ampac, LoopSense, fire alarm control panel and may be subject to change. Complete and current details should be determined from the designated producer's technical manual/data sheets.

| Mechanical | | |
|---|---|-----------------------------------|
| Dimensions Cabinet: | | |
| SPX 1 | 500 mm (H) x 405 mm (W) x 150 mm (D) | |
| SPX 8 | 840 mm (H) x 515 mm (W) x 170 mm (D) | |
| Environmental | | |
| Temperature: | 0°C to + 40°C | |
| Humidity: | 25% to 95% non condensing | |
| Power Supply Mains Input | | |
| | 3 Amp | 6 Amp |
| Input Voltage: | 204 – 264 Vac | 204 – 264 Vac |
| Protection (Quick Acting Fuse): | 2 Amp M205 | 5 Amp M205 |
| Minimum Cable Requirements: | Not less than 0.75mm ² | Not less than 0.75mm ² |
| Power Supply | | |
| Voltage with Mains connected: | 25 – 29VDC | 25 – 29VDC |
| Power Supply Ripple Voltage: | <100 mV | <100 mV |
| Power Supply Fault Indication | | |
| Volts High (at room temperature) | 28 Vdc | 28 Vdc |
| Volts Low | 26.5 Vdc | 26.5 Vdc |
| Power Supply Output Current | 3 Amps | 6 Amps |
| I _{max, A} | 3 Amps | 6 Amps |
| Protection: | Current Limiting | Current Limiting |
| Batteries / Battery Charger | | |
| Charger O/P Voltage (temperature compensated): | 26.6-28.1 Vdc (27.3 Vdc Nom.) | 26.6-28.1 Vdc (27.3 Vdc Nom.) |
| Battery Type: | 2 x 12 V Sealed Lead Acid | 2 x 12 V Sealed Lead Acid |
| | 17.2 AH | 26 AH |
| Maximum Battery Capacity: | 600 mA | 1 A |
| Max Charger Current Limited: | 3 A and 2 A PTC | 3 A and 2 A PTC |
| Battery Supply Current Limited: | <23.5 Vdc | <23.5 Vdc |
| Battery Low: | <21 Vdc | <21 Vdc |
| Battery Discharged Cut-off Voltage: | <22 Vdc | <22 Vdc |
| Battery Damaged: | 1.2Ω | 1.2Ω |
| Max Battery Resistance | | |
| Main Card | | |
| Quiescent Current (QI) 1 Loop | 115 mA | |
| 1 Loop in Alarm (Min) | 155 mA | |
| Quiescent Current (QI) 2 Loop | 135 mA | |
| 2 Loop in Alarm (Min) | 180 mA | |
| Loop | | |
| Maximum number of Zones: | 40 in total (for 1 or 2 loop panel) | |
| Maximum Number of Devices: | 126 maximum | |
| Loop Current | 500 mA max | |
| Cabling Requirements: | 2 core 1.5 to 2.5 mm ² Max length 1 km | |
| Fault supervision: | O/C, S/C | |
| Outputs | | |
| Supervised Alarm (Current Limited) | 24 Vdc @ 500 mA Max | |
| Alarm / Fault Relay Contacts | 24 Vdc @ 1 A | |
| Auxiliary Vdc – Protected | 24 Vdc 500 mA | |
| Cabling Requirements | 2 core 1.5 to 2.5 mm ² Max length 1 km | |
| Inputs | | |
| Supervised | O/C, S/C, 10K EOL | |
| Cabling Requirements | 2 core 1.5 to 2.5 mm ² Max length 1 km | |
| Communications | | |
| Internal to FACP | RS485 | |
| External to FACP | RS485 | |

Schedule to Certificate of Conformity

| | | | | |
|-------------------|-------------------|--------------|---------------------------|-------------|
| Certificate num. | Registration date | Version | Valid until | |
| afp - 2802 | 15-Feb-2013 | Number 15 | Issue date 15-Apr-2026 | 30-Apr-2027 |

Schedule of components

The following is a schedule of validated components of the certified/listed the minimum system build for the Ampac, LoopSense, fire alarm control panel to conform with the requirements of the conformance criteria:

| Description | Reference | Issue date |
|----------------------------|------------|------------|
| Indicator and control card | BR82ICCS | 17/01/12 |
| 1-2 Loop Main board | BRD82MBA7 | 16/01/12 |
| Power supply unit | BRD35PSU-B | 15/9/2009 |

Additional expansion components/modules which also conform with applicable requirements of the conformance criteria include:

| Description | Reference | Issue date |
|--|----------------------|------------|
| Fan control board | BRD25FCB-A | 17/1/08 |
| Conventional zone board | BRD43EZC2-A | 12/2/09 |
| General indicator board | BRD25GIB3 | 19/08/03 |
| 32 Zone Alarm/Fault mimic card | BRD43ZAMC2-A | 06/02/07 |
| Fan termination board | BRD25FTB3-A | 180803 |
| 8 way relay board | BRD25EWRB4 | 1/4/05 |
| 8-way sounder board | BRD25SOPB | 8/2/2008 |
| Agent release board | BRD25ARB6-A | 17/1/08 |
| Agent termination board | BRD25ATB5-A | 15/06/04 |
| Alarm acknowledgement module | BRD42AAF2-A S/W V1.3 | |
| Smart Terminal remote fire brigade panel /mimic (comprising Indicator and control card | BR82ICCS | 17/01/12 |
| LCD termination board | BRD82LTB2 | 8/09/06 |

Supplementary information

Schedule of relevant articles

The following schedule is an extract of articles significant and/or related as evidence of conformity.

| Reference | | Title / description | Date issued (or date validated) | Source |
|-------------|---------------|--|------------------------------------|--|
| Ident. type | Ident. | | | |
| Report | XF2490/R1b | Evaluation for conformity of the Ampac LoopSense fire alarm control panel to the requirements of AS 7240.2-2004 AS 7240.4-2004 AS 4428.3-2010 | 15-Feb-2013 | CSIRO, Materials Science and Engineering, Fire Systems, AU |
| Report | XF2490/R2-SWb | Evaluation for conformity of the Ampac LoopSense fire alarm control panel to the requirements of Section 14 of AS 7240.2-2004 | 15-Feb-2013 | CSIRO, Materials Science and Engineering, Fire Systems, AU |
| Manual | MAN 1560-2 | Fire Alarm Control Panel (AS4428 & AS7240. 2 & 4) Installation and Commissioning | 4-Dec-2012 | Ampac Technologies Pty Ltd, WA, AU |
| Manual | MAN1567-2 | AS4428 and AS7240. 2 & 4 Fire Alarm Control Panel Operation & On Site Programming | 23-Apr-2012 | |